

## **ChenYang Standard Soft Ferrite Cores**

**Copyright© 2006, ChenYang Technologies GmbH & Co. KG**

All rights reserved. No part of this catalogue may be reproduced, stored in a retrieval system or transmitted in any form or by any means, electronic, mechanical, photocopying, recording or otherwise, without the prior permission of the copyright holder.

**Contact Address:**

Markt Schwabener Str. 8  
D-85464 Finsing  
Germany

Tel: +49 (0)8121-2574100, 2574109  
Fax: +49 (0)8121-2574101  
Email: [info@cy-magnetics.com](mailto:info@cy-magnetics.com)  
<http://www.cy-magnetics.com>

## AP/AR Cores of Soft Ferrite

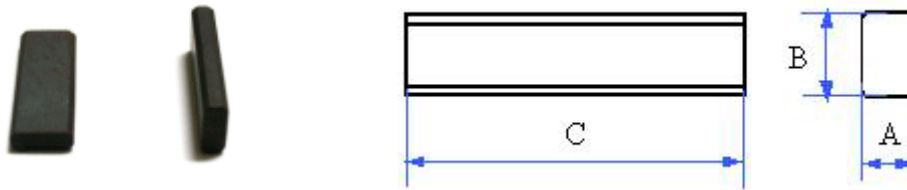

Cores	A (mm)	B (mm)	C (mm)
AP2x8x50	2.0 +0.1 / -0.3	8.0 +0 / -0.5	50.0 ±1.2
AP3x6x40	3.0 +0.1 / -0.3	6.0 +0 / -0.4	40.0 ±1.0
AP3x8x40	3.0 +0.1 / -0.3	8.0 +0 / -0.5	40.0 ±1.0
AP3x8x45	3.0 +0.1 / -0.3	8.0 +0 / -0.5	45.0 ±1.0
AP3x8x50	3.0 +0.1 / -0.3	8.0 +0 / -0.5	50.0 ±1.2
AP4x8x40	4.0 +0 / -0.4	8.0 +0 / -0.5	40.0 ±1.0
AP4x8x45	4.0 +0 / -0.4	8.0 +0 / -0.5	45.0 ±1.0
AP4x8x50	4.0 +0 / -0.4	8.0 +0 / -0.5	50.0 ±1.2
AP4x10x45	4.0 +0 / -0.4	10.0 +0 / -0.6	45.0 ±1.0
AP4x10x50	4.0 +0 / -0.4	10.0 +0 / -0.6	50.0 ±1.2
AP5x10x45	5.0 +0 / -0.4	10.0 +0 / -0.6	45.0 ±1.0
AP5x10x55	5.0 +0 / -0.4	10.0 +0 / -0.6	55.0 ±1.2
AP4x13x45	5.0 +0 / -0.4	13.0 +0 / -0.6	45.0 ±1.0
AP5x13x55	5.0 +0 / -0.4	13.0 +0 / -0.6	55.0 ±1.2

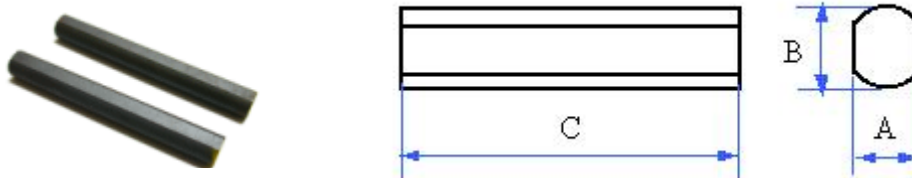

Cores	A (mm)	B (mm)	C (mm)
AR8x50	8.0 +0 / -0.5	7.2 +0.2 / -0.5	50.0 ±1.2
AR8x60	8.0 +0 / -0.5	7.2 +0.2 / -0.5	60.0 ±1.4
AR8x65	8.0 +0 / -0.5	7.2 +0.2 / -0.5	65.0 ±1.4
AR8x70	8.0 +0 / -0.5	7.2 +0.2 / -0.5	70.0 ±1.6
AR8x80	8.0 +0 / -0.5	7.2 +0.2 / -0.5	80.0 ±1.6
AR8x85	8.0 +0 / -0.5	7.2 +0.2 / -0.5	85.0 ±1.6
AR8x100	8.0 +0 / -0.5	7.2 +0.2 / -0.5	100.0 ±1.8
AR10x50	10.0 +0 / -0.6	9.0 +0.2 / -0.5	50.0 ±1.2
AR10x60	10.0 +0 / -0.6	9.0 +0.2 / -0.5	60.0 ±1.4
AR10x70	10.0 +0 / -0.6	9.0 +0.2 / -0.5	70.0 ±1.6
AR10x80	10.0 +0 / -0.6	9.0 +0.2 / -0.5	80.0 ±1.6
AR10x100	10.0 +0 / -0.6	9.0 +0.2 / -0.5	100.0 ±1.8
AR10x110	10.0 +0 / -0.6	9.0 +0.2 / -0.5	110.0 ±1.8
AR10x120	10.0 +0 / -0.6	9.0 +0.2 / -0.5	120.0 ±1.8

# DR Cores and DRWW Cores of Soft Ferrite

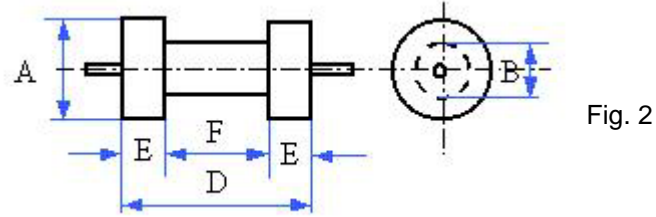
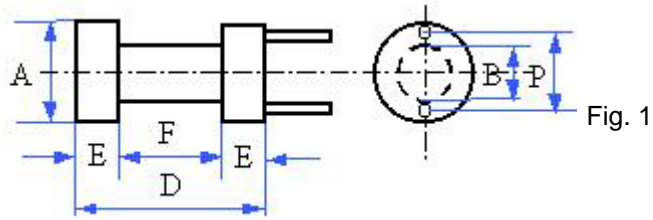

Type	Dimensions (Unit: mm)						Tpye with wire
	A	B	D	F	P	Fig.	
DR2.3x4D-29	2.3 ±0.1	1.4 ±0.15	4 ±0.2	1.8 ±0.1	-	2	DRWW2.3x4D
DR3x6D-29	3 ±0.1	1.8 ±0.15	6 ±0.2	3.6 ±0.15	-	2	DRWW3x6D
DR5x13D-29	5 ±0.15	3.2 ±0.15	13 ±0.4	10.15 ±0.2	-	2	DRWW6x13D
DR6x15D-29	6 ±0.15	3 ±0.15	15 ±0.4	9 ±0.2	-	2	DRWW6x15D
DR4x6D-31	4 ±0.1	2.2 ±0.15	6 ±0.2	3 ±0.15	2 ±0.5	1	DRWW4x6N
DR6x8D-31	6 ±0.15	3 ±0.15	8 ±0.3	4.2 ±0.15	3 ±0.5	1	DRWW6x8N
DR8x10D-31	8 ±0.15	4 ±0.15	10 ±0.3	6 ±0.15	5 ±0.5	1	DRWW8x10N
DR8x12D-31	8 ±0.15	4.5 ±0.15	12 ±0.15	6.5 ±0.15	5 ±0.5	1	DRWW8x12N
DR8x20D-31	8 ±0.15	5 ±0.15	20 ±0.2	13.8 ±0.2	5 ±0.5	1	DRWW8x20N
DR9x12D-31	9 ±0.2	4 ±0.15	12 ±0.4	7 ±0.15	5 ±0.5	1	DRWW9x12N
DR10x11D-31	10 ±0.2	3.8 ±0.15	11 ±0.3	6.5 ±0.15	7 ±0.5	1	DRWW10x11N
DR10x12D-31	10 ±0.2	4.1 ±0.15	12 ±0.4	7 ±0.15	6 ±0.5	1	DRWW10x12N
DR10x15D-31	10 ±0.2	5.3 ±0.15	15 ±0.4	10 ±0.2	6 ±0.5	1	DRWW10x15N
DR10x16D-31	10 ±0.2	5 ±0.15	16 ±0.5	10.5 ±0.2	7 ±0.5	1	DRWW10x16N
DR12x15D-31	12 ±0.2	6 ±0.15	15 ±0.4	9 ±0.2	7.5 ±0.5	1	DRWW12x15N
DR14x15D-31	14 ±0.2	6 ±0.15	15 ±0.4	9 ±0.2	7.5 ±0.5	1	DRWW14x15N
DR16x18D-31	16 ±0.2	5.3 ±0.15	18 ±0.5	13 ±0.2	7.5 ±0.5	1	DRWW16x18N
DR14x19D-31	14 ±0.2	4 ±0.15	19 ±0.5	13 ±0.2	7.5 ±0.5	1	DRWW14x19N
DR18x18D-31	18 ±0.2	10 ±0.2	18 ±0.5	13 ±0.2	13 ±0.5	1	DRWW18x18N
DR18x22D-31	18 ±0.2	11 ±0.2	20 ±0.6	13.7 ±0.2	10 ±0.5	1	DRWW18x22N

## DRH/DRUM Cores of Soft Ferrite

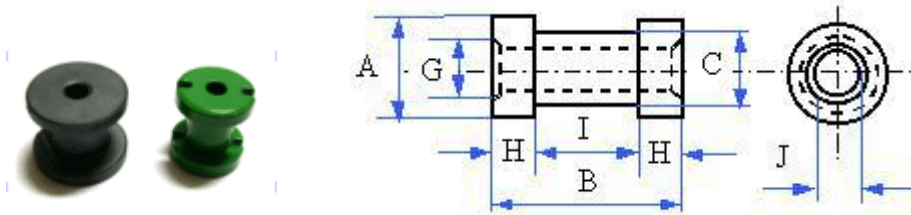

Type	Dimensions (Unit: mm)						
	A	B	C	G	H	I	J
DRH18x20R	18.03 ±0.8	20 ±1.0	11 ±0.4	4.75 ±0.3	3.75	12.5 ±0.5	3.2 ±0.2
DRH22x19	22 ±1.0	18.5 ±0.5	13 ±0.3	6.3 ±0.3	3 ±0.2	13 ±0.5	5.35 ±0.2
DRH25x25	26 ±1.0	25 ±1.0	13.5 ±0.5	6.3 ±0.3	4 ±0.2	17 ±0.5	5.35 ±0.3

## EE Cores of Soft Ferrite

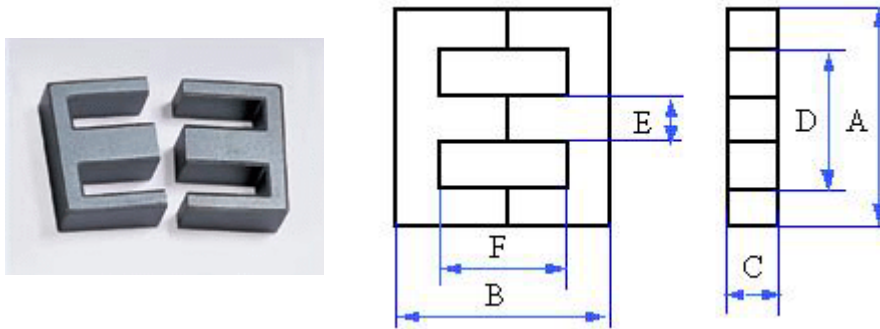

### Dimensions

Type	Dimensions (Unit: mm)					
	A	B	C	D	E	F
EE5	5.25 ±0.1	5.3 ±0.14	1.95 ±0.1	4.0 ±0.2	1.35 ±0.1	4.0 ±0.15
EE6.3	6.3 +0 <sub>-0.5</sub>	5.8 ±0.2	1.9 ±0.1	3.6 +0.2 <sub>-0</sub>	1.4 +0 <sub>-0.10</sub>	3.7 +0.1 <sub>-0.0</sub>
EE8.3	8.3 ±0.2	8.0 ±0.2	3.9 ±0.15	6.0 ±0.3>	2.0 ±0.3	6.0 ±0.2
EE8.6	8.6 ±0.2	8.6 ±0.15	3.8 ±0.2	6.5 ±0.2	2.1 +0 <sub>-0.3</sub>	6.4 ±0.2
EE9.4	9.4 ±0.4	10.7 ±0.3	2.35 ±0.1	5.8 ±0.15	2.32 ±0.15	7.4 ±0.3
EE10A	10.2 ±0.3	11.0 ±0.4	9.8 +0.3 <sub>-0.1</sub>	7.6 <sub>min</sub>	2.4 ±0.2	8.6 ±0.4
EE10	10.2 ±0.3	11.0 ±0.4	4.9 ±0.3	7.6 <sub>min</sub>	2.5 ±0.2	8.6 ±0.4
EE12	12.2 ±0.3	10.6 ±0.2	3.9 ±0.2	8.8 <sub>min</sub>	3.2 ±0.2	7.2 ±0.4
EE12.5	12.5 ±0.3	14.8 ±0.4	5.0 ±0.2	9.2 <sub>min</sub>	2.4 ±0.2	10.2 ±0.4
EE12.7	12.7 ±0.4	12.8 ±0.4	3.6 ±0.2	8.8 <sub>min</sub>	3.7 ±0.2	9.3 ±0.4
EE13	13.1 ±0.3	12.0 ±0.3	5.9 ±0.25	10.0 <sub>min</sub>	2.8 ±0.4	9.2 ±0.3
EE13A	13.0 ±0.3	12.0 ±0.3	9.8 ±0.3	8.5 <sub>min</sub>	3.6 ±0.2	9.2 ±0.2

Type	Dimensions (Unit: mm)					
	A	B	C	D	E	F
EE14	14.0 ±0.3	7.0 ±0.2	5.0 ±0.15	10.9 ±0.3	3.0 ±0.2	4.0 ±0.3
EE16A	16.0 ±0.3	14.4 ±0.3	5.0 ±0.2	12.0 ±0.3	4.0 ±0.2	10.4 ±0.3
EE16B	16.0 ±0.4	24.4 ±0.4	5.0 ±0.20	11.7 <sub>min</sub>	4.0 ±0.20	20.4 ±0.30
EE16C	16.0 ±0.3	8.8 ±0.2	10.1 ±0.30	11.7 <sub>min</sub>	4.15 ±0.15	5.9 ±0.30
EE16D	16.0 ±0.5	16.6 ±0.4	4.5 ±0.20	11.3 <sub>min</sub>	4.7 ±0.20	11.4 ±0.30
EE16E	16.0 ±0.5	16.6 ±0.4	8.2 ±0.20	11.3 <sub>min</sub>	4.7 ±0.20	11.4 ±0.30
EE17.7	17.7 ±0.3	20.2 ±0.4	5.6 ±0.15	13.1 <sub>min</sub>	7.8 ±0.2	15.0 ±0.3
EE19A	19.0 ±0.4	16.2 ±0.3	4.85 ±0.25	14.2 <sub>min</sub>	4.85 ±0.25	11.3 ±0.3
EE19B	19.0 ±0.4	27.2 ±0.5	4.85 ±0.25	14.0 <sub>min</sub>	4.85 ±0.25	22.6 ±0.3
EE19C	19.0 ±0.4	16.2 ±0.3	9.5 ±0.25	14.2 <sub>min</sub>	4.75 ±0.2	11.4 ±0.3
EE20	20.5 ±0.3	21.7 ±0.5	7.0 ±0.2	14.7 <sub>min</sub>	5.0 ±0.3	14.0 ±0.5
EE20A	20.3 ±0.4	16.8 ±0.4	4.8 ±0.2	15.3 <sub>min</sub>	4.8 ±0.2	12.4 ±0.4
EE20B	20.0 ±0.4	20.3 ±0.5	9.2 ±0.25	15.2 <sub>min</sub>	4.5 ±0.2	15.8 ±0.4
EE20C	20.0 ±0.6	18.0 ±0.7	10.8 ±0.3	14.1 <sub>min</sub>	5.7 ±0.2	12.6 ±0.4
EE22	22.0 ±0.4	20.0 ±0.6	5.5 ±0.3	17.0 <sub>min</sub>	4.0 ±0.2	15.0 ±0.4
EE22A	21.7 ±0.4	23.8 ±0.5	5.8 ±0.3	15.5 <sub>min</sub>	5.8 ±0.3	16.2 ±0.4
EE22B	22.0 ±0.4	18.4 ±0.4	5.7 ±0.3	16.7 ±0.4	5.75 ±0.25	10.8 ±0.4
EE22C	21.7 ±0.4	19.1 ±0.5	5.8 ±0.3	15.5 <sub>min</sub>	5.8 ±0.3	11.0 ±0.4
EE22D	22.0 ±0.4	30.0 ±0.5	5.8 ±0.2	16.0 ±0.4	5.8 ±0.2	22.0 ±0.4
EE23	22.7 ±0.4	22.0 ±0.6	10.0 ±0.2	16.4 <sub>min</sub>	7.5 ±0.3	15.0 ±0.3
EE25A	25.0 ±0.5	19.8 ±0.6	6.1 ±0.2	18.6 <sub>min</sub>	5.8 ±0.2	13.8 ±0.5
EE25B	25.4 ±0.5	19.6 ±0.4	6.35 ±0.3	18.6 <sub>min</sub>	6.35 ±0.2	13.6 ±0.4
EE25C	25.4 ±0.5	19.8 ±0.4	6.35 ±0.25	19.0 ±0.4	6.35 ±0.25	13.4 ±0.4
EE25D	25.4 ±0.5	31.8 ±0.6	6.35 ±0.25	19.0 ±0.4	6.35 ±0.3	25.4 ±0.6
EE25E	25.0 ±0.5	25.1 ±0.5	7.2 ±0.3	17.5 <sub>min</sub>	7.25 ±0.25	17.9 ±0.5
EE25F	25.4 ±0.5	25.1 ±0.5	11.0 ±0.3	17.5 <sub>min</sub>	7.25 ±0.25	17.9 ±0.5
EE25G	25.0 ±0.5	25.0 ±0.6	7.0 ±0.4	17.5 <sub>min</sub>	6.8 ±0.3	18.2 ±0.4
EE26A	26.0 ±0.7	19.6 ±0.4	9.8 ±0.2	18.2 <sub>min</sub>	8.5 ±0.2	11.8 ±0.4
EE26B	25.8 ±0.5	21.2 ±0.5	9.9 ±0.3	17.9 <sub>min</sub>	8.4 ±0.2	12.6 ±0.4
EE27	27.0 ±0.5	21.6 ±0.4	11.0 ±0.3	19.7 ±0.5	7.4 ±0.2	14.0 ±0.4
EE28A	28.0 ±0.5	33.6 ±0.6	7.45 ±0.25	18.6 <sub>min</sub>	7.25 ±0.25	24.6 ±0.6
EE28B	28.0 ±0.6	21.0 ±0.6	11.5 ±0.3	18.6 <sub>min</sub>	7.7 ±0.3	11.8 ±0.6
EE28C	28.0 ±0.5	32.4 ±0.4	10.6 ±0.3	18.6 <sub>min</sub>	7.2 ±0.25	24.6 ±0.6
EE28D	28.0 ±0.8	24.4 ±0.3	8.9 ±0.25	19.4 <sub>min</sub>	8.89 ±0.25	16.4 ±0.4
EE28E	28.5 ±0.5	33.4 ±0.4	10.8 ±0.2	19.2 <sub>min</sub>	7.3 ±0.2	24.7 ±0.2
EE28F	28.0 ±0.5	22.0 ±0.6	10.6 ±0.3	18.6 <sub>min</sub>	7.2 ±0.3	12.8 ±0.6
EE28G	28.2 ±0.5	27.5 ±0.4	10.7 ±0.2	20.5 ±0.3	7.9 ±0.2	19.8 ±0.3
EE29	29.3 ±0.3	29.2 ±0.4	11.9 ±0.2	21.6 <sub>min</sub>	8.4 ±0.2	22.0 ±0.4
EE30A	30.5 ±0.5	30.0 ±0.6	7.0 ±0.3	19.5 <sub>min</sub>	6.9 ±0.3	20.4 ±0.6
EE30B	30.0 ±0.5	26.2 ±0.4	10.7 ±0.3	19.7 <sub>min</sub>	10.7 ±0.3	16.2 ±0.4
EE32A	32.1 ±0.8	25.8 ±0.4	7.65 ±0.35	22.7 <sub>min</sub>	9.2 ±0.3	16.4 ±0.6
EE32B	32.1 ±0.8	32.2 ±0.4	9.15 ±0.35	22.7 <sub>min</sub>	9.2 ±0.3	23.0 ±0.6
EE32C	31.75 ±0.65	12.7 ±0.3	20.3 ±0.5	24.9 <sub>min</sub>	6.35 ±0.15	6.4 ±0.4
EE33	33.0 ±0.6	28.0 ±0.6	12.7 ±0.3	22.8 <sub>min</sub>	9.7 ±0.3	19.2 ±0.4
EE35A	35.0 ±0.6	29.2 ±0.6	9.2 ±0.3	24.8 <sub>min</sub>	9.4 ±0.3	19.2 ±0.4
EE35B	34.5 ±0.8	28.6 ±0.7	9.5 ±0.4	25.4 <sub>min</sub>	9.4 ±0.3	19.4 ±0.3

Type	Dimensions (Unit: mm)					
	A	B	C	D	E	F
EE35C	35.0 ±0.5	48.8 ±0.4	10.0 ±0.3	24.5 <sub>min</sub>	10.0 ±0.3	36.6 ±0.4
EE38	38.1 ±0.8	16.6 ±0.3	25.4 ±0.5	30.2 <sub>min</sub>	7.6 ±0.3	9.0 ±0.4
EE40A	40.0 ±0.6	34.0 ±0.6	10.7 ±0.2	27.6 <sub>min</sub>	10.7 ±0.3	20.5 ±0.5
EE40B	40.0 ±0.7	34.6 ±0.6	11.75 ±0.25	26.8 <sub>min</sub>	11.75 ±0.25	20.8 ±0.4
EE41	40.6 ±0.6	33.0 ±0.4	12.5 ±0.3	28.6 <sub>min</sub>	12.5 ±0.3	21.0 ±0.6
EE41B	41.5 ±0.6	34.0 ±0.4	12.7 ±0.3	29.0 <sub>min</sub>	12.5 ±0.3	21.2 ±0.4
EE42A	42.0 ±0.8	42.4 ±0.8	11.85 ±0.35	29.5 <sub>min</sub>	11.9 ±0.3	30.2 ±0.4
EE42B	42.0 ±0.8	42.4 ±0.8	14.9 ±0.3	29.5 <sub>min</sub>	11.9 ±0.3	30.2 ±0.4
EE42C	42.0 ±0.8	42.4 ±0.8	19.85 ±0.35	29.5 <sub>min</sub>	11.9 ±0.3	30.2 ±0.4
EE42D	42.0 ±0.5	42.6 ±0.6	19.85 ±0.35	30.0 <sub>min</sub>	12.25 ±0.25	31.7 ±0.5
EE43	43.0 ±0.9	19.0 ±0.3	27.9 ±0.6	34.7 <sub>min</sub>	8.1 ±0.2	10.8 ±0.4
EE46	46.4 ±0.6	37.1 ±0.5	9.4 ±0.3	31.6 <sub>min</sub>	15.9 ±0.3	22.8 ±0.6
EE50	50.0 ±0.5	59.0 ±0.4	24.0 ±0.2	35.0 ±0.3	15.0 ±0.2	44.0 ±0.4
EE55A	55.15 ± 1.05	55.0 ±0.6	21.0 ±0.7	37.5 <sub>min</sub>	16.9 ±0.3	37.6 ±0.6
EE55B	55.15 ± 1.05	55.0 ±0.6	24.7 ±0.4	37.5 <sub>min</sub>	16.9 ±0.3	37.6 ±0.6
EE65A	65.2 ± 1.3	65.0 ±0.6	27.0 ±0.4	44.2 <sub>min</sub>	19.65 ±0.35	45.1 ±0.7
EE65B	65.0 ± 1.3	65.0 ±0.6	19.3 ±0.7	43.0 <sub>min</sub>	19.8 ±0.2	48.1 ±1.2
EE70A	70.5 ± 1.5	71.0 ±1.0	24.5 ±0.6	48.0 <sub>min</sub>	16.7 ±0.5	49.3 ±1.3
EE70B	70.75 ± 1.5	66.4 ±0.8	30.5 ±0.6	48.0 <sub>min</sub>	21.5 ±0.5	44.0 ±1.2
EE80	80.5 ± 1.5	76.0 ±1.0	20.0 ±0.5	59.8 <sub>min</sub>	20.0 ±0.5	56.0 ±1.0
EE85A	85.0 ± 2.5	88.0 ±2.0	26.5 ±0.5	55.0 <sub>min</sub>	27.2 ±0.6	57.4 ±1.0
EE85B	85.0 ± 2.5	88.0 ±2.0	31.5 ±0.5	55.0 <sub>min</sub>	27.2 ±0.6	57.4 ±1.0
EE90	90.0 ± 2.0	56.4 ±1.0	16.5 ±0.5	64.0 <sub>min</sub>	25.0 ±1.0	31.4 ±1.0
EE110	110.0 ± 2.5	112.0 ±2.0	36.0 ±1.0	74.2 <sub>min</sub>	36.0 ±1.0	74.4 ±2.8
EE118	118 ± 2.5	173 ±2.0	35.0 ±0.7	82.0 <sub>min</sub>	35.0 ±0.5	138 ±2.5
EE128	130 ± 3.0	126 ±2.0	20.0 ±1.0	89.0 <sub>min</sub>	40.0 ±1.0	86.0 ±1.0
EE160	162 ± 2.5	166 ±2.0	20.0 ±1.5	120 <sub>min</sub>	40.0 ±0.2	128 ±1.0
EE185	185 ± 3.5	154.0 ±3.0	27.5 ±1.0	128 <sub>min</sub>	53.0 ±1.0	100 ±3.0
EE320	320 ± 5.0	250 ±1.5	20.0 ±2.0	217 <sub>min</sub>	100 ±2.5	150 ±3.0

## Core Set Parameters and Electrical Characteristics

AL-Value (nH/N<sup>2</sup> ±25%): 1kHz, 0.25V, 100Ts, 25±3°C

Type	C1 (mm)	Ae (mm <sup>2</sup> )	Le (mm <sup>-1</sup> )	Ve (mm <sup>3</sup> )	AL for Material						Weight (g)
					CY-MP3	CY-MP2B	CY-MP2A	CY-HP5	CY-HP7	CY-HP10	
EE5	4.9	26	12.7	32.5	-	-	270	-	-	980	0.2
EE6.3	3.5	34	12	41.1	-	-	360	-	-	-	0.25
EE8.3	2.4	8.0	19.3	154.4	-	-	675	-	-	-	0.92
EE9	3.3	6.8	22.6	153.7	850	700	650	-	-	-	1.0
EE10A	1.1	23.1	26.4	611.6	2500	2100	1900	-	-	-	3.2
EE10	2.1	12.2	26.1	330.7	950	800	800	1400	1650	2500	1.8
EE12	2.0	12.9	25.4	328	1100	1000	900	-	-	-	3.8
EE12.5	2.2	14.7	31.6	462.8	1250	1000	900	-	-	-	2.8
EE12.7	2.4	12.4	29.7	369	1100	900	800	-	-	-	2.0
EE13	0.52	15.4	29.6	456	950	900	900	1700	1900	3200	3.6
EE13A	1.2	35.6	29.8	1062	2600	2300	2100	-	-	-	5.9
EE14	1.4	15.1	20.7	311.3	2000	1600	1500	-	-	-	1.6

Type	C1 (mm)	Ae (mm <sup>2</sup> )	Le (mm <sup>-1</sup> )	Ve (mm <sup>3</sup> )	AL for Material						Weight (g)
					CY- MP3	CY- MP2B	CY- MP2A	CY- HP5	CY- HP7	CY- HP10	
EE16A	1.92	18.4	35.5	655	1200	1100	1000	1900	2100	3400	3.3
EE16B	2.8	19.6	55.2	1080	900	850	800	1550	1750	2550	5.3
EE16C	0.6	39.9	23.9	953.8	4700	3900	3600	-	-	-	3.3
EE16D	1.87	20.1	37.6	750	1500	1200	1100	-	-	-	4.0
EE16E	0.9	39.9	36.2	1443.1	1500	1200	1100	-	-	-	4.5
EE17.7	1.4	29.1	41.9	1218.4	2000	1600	1500	-	-	-	7.5
EE19A	1.68	23.3	39.2	914	1200	1100	1000	2200	2500	3500	4.6
EE19B	2.65	23.4	62.1	1450	1000	840	840	-	-	-	7.5
EE19C	0.9	44.5	39.9	1777.5	2000	1800	1700	-	-	-	9.2
EE20	1.21	39	47.1	1840	2100	1900	1800	-	-	-	9.7
EE20A	1.9	22	42.8	942.8	1500	1200	1100	-	-	-	4.9
EE20B	1.2	41.1	49.7	2042	2300	1950	1800	-	-	980	11
EE20C	0.6	66.9	42.2	2812.8	3500	3000	2800	-	-	-	13
EE22A	1.3	39.7	51.8	2056.2	1800	1550	1500	-	-	-	9.9
EE22B	1.0	39.5	40.2	1587.9	-	2300	2100	3800	4500	6650	-
EE22C	1.0	39.6	41.5	1645.1	2100	1800	1700	-	-	-	6.8
EE22D	1.8	35.7	63.9	2281.2	-	1350	1250	2400	3100	4100	-
EE23	0.75	70	49.6	3469	-	2300	2200	-	-	-	10.2
EE25A	1.25	39.6	49.5	1963	2000	1800	1700	-	-	-	15
EE25B	1.3	36.9	49.4	1823	1900	1800	1700	-	-	-	14
EE25C	1.2	40.4	48.0	1939.2	-	1900	1750	3400	4150	5900	-
EE25D	1.8	39.8	73.5	2925.3	-	1250	1150	2500	3100	4100	-
EE25E	1.1	51.4	57.8	2974	2000	1800	1700	-	-	-	20
EE25F	0.72	80.4	57.8	4647.1	3900	3200	3000	-	-	-	24
EE25G	1.2	49.2	57.9	2850	2300	1900	1800	-	-	-	21
EE26A	0.6	75.3	46.1	3470.4	4700	3900	3600	-	-	-	19
EE26B	0.6	80.0	48.0	3839.3	4700	3900	3600	-	-	-	24
EE27	0.6	83.5	51.7	4320.1	4700	3900	3600	-	-	-	22
EE28A	0.95	71.6	63.0	4508	3400	3060	2850	-	-	-	35
EE28B	0.57	99.8	48.1	4801	4500	4000	3800	-	-	-	23.5
EE28C	0.82	87.4	73.1	6391	3500	2900	2700	-	-	-	33.5
EE28D	0.82	87.4	73.1	6391	3500	2900	2700	-	-	-	35
EE28E	0.9	87.5	74.4	6508	3100	2600	2400	-	-	-	35
EE28F	0.6	88.1	50.5	4451	4000	3400	3200	-	-	-	24
EE28G	0.8	83.1	64.4	5351	3505	2900	2700	-	-	-	26
EE29	0.8	94	69.1	6285	3500	2900	2700	-	-	-	32
EE30A	1.15	57.3	66.1	3790	2000	1900	1800	-	-	-	22
EE30B	0.53	110	57.9	6360	4500	4200	4000	-	-	-	33
EE32A	0.92	70.1	61.3	4295	3000	2500	2300	-	-	-	21.5
EE32B	0.89	83	74	6140	2800	2400	2300	-	-	-	32
EE32C	0.3	127.7	41.9	5346	9500	7800	7000	-	-	-	28
EE33	0.62	110	67.7	7520	4500	4000	3800	-	-	-	40.6
EE35A	0.8	86.2	69.3	5973	3500	2900	2700	-	-	-	31
EE35B	0.83	88.3	69.4	6121	3400	2800	2600	-	-	-	33
EE38	0.3	189.9	53.1	10087	9000	7800	7200	-	-	-	38
EE40A	0.6	127	77.0	9922	4500	3800	3600	-	-	-	50
EE40B	0.5	153	76.5	11710	4800	3800	3600	-	-	-	60
EE41	0.5	152	77.1	11722	4800	4000	3800	-	-	-	63
EE42A	0.7	147.4	96.8	14275	4000	3300	3000	-	-	-	72
EE42B	0.5	184.3	96.8	17843	4800	4000	3800	-	-	-	90
EE42C	0.4	235	97.4	22889	6000	5000	4800	-	-	-	120
EE42D	0.4	232.1	98.0	22755	7000	5500	5200	-	-	-	120

Type	C1 (mm)	Ae (mm <sup>2</sup> )	Le (mm <sup>-1</sup> )	Ve (mm <sup>3</sup> )	AL for Material						Weight (g)
					CY- MP3	CY- MP2B	CY- MP2A	CY- HP5	CY- HP7	CY- HP10	
EE43	0.3	224	61.7	13812	9000	7500	7200	-	-	-	130
EE46	0.6	140.7	84.6	11883	4500	3900	3600	-	-	-	62
EE50	0.4	360	131.6	47323	7000	5800	5400	-	-	-	238
EE55A	0.35	354	123	43542	8000	6700	6500	-	-	-	216
EE55B	0.3	420.4	123.4	51878	9000	7800	7200	-	-	-	264
EE65A	0.27	540	147	79000	10000	8500	7900	-	-	-	410
EE65B	0.4	378.9	147	58656	7000	5800	5400	-	-	-	285

## EED Cores of Soft Ferrite

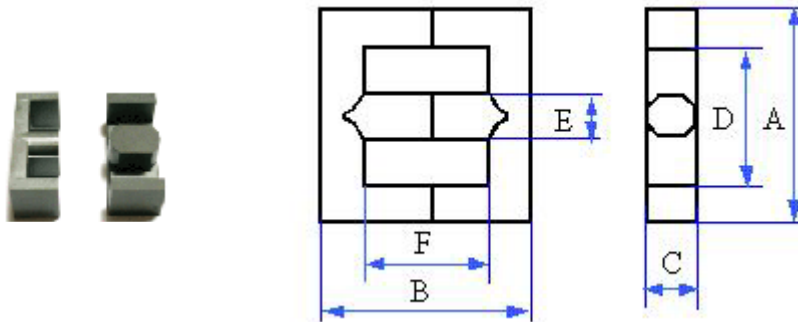

### Dimensions

Type	Dimensions (Unit: mm)					
	A	B	C	D	E	F
EED28	28.0 ±0.5	20.8 ±0.5	11.7 ±0.3	20.5 <sub>min</sub>	8.5 ±0.2	13.4 ±0.5
EED29	29.8 ±0.8	29.6 ±0.4	11.60 ±0.2	21.8 <sub>min</sub>	8.4 ±0.2	22.4 ±0.4

### Core Set Parameters and Electrical Characteristics

AL-Value (nH/N<sup>2</sup> ±25%): 1kHz, 0.25V, 100Ts, 25±3°C

Type	Le (mm)	Ae (mm <sup>2</sup> )	C1 (mm <sup>-1</sup> )	Ve (mm <sup>3</sup> )	AL for Material				
					CY- MP2B	CY- MP2A	CY- HP5	CY- HP7	CY- HP10
EED28	50.5	86.1	0.6	4348.1	3130	2870	-	-	-

## EER Cores of Soft Ferrite

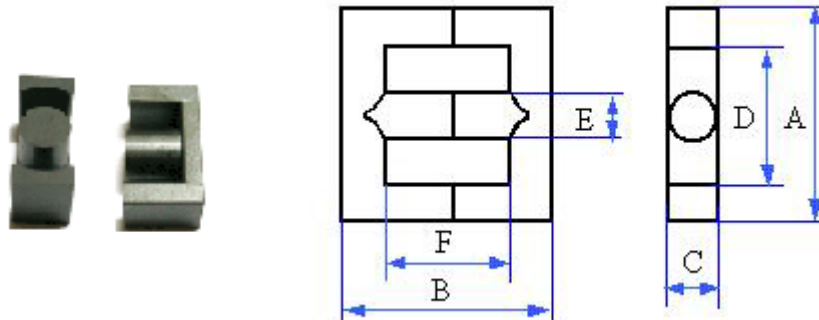

### Dimensions

Type	Dimensions (Unit: mm)					
	A	B	C	D	E	F
EER9/5	9.35 ±0.15	4.90 ±0.10	4.90 ±0.10	7.40 <sub>min</sub>	3.40 ±0.10	3.34 ±0.14
EER12/5	11.80 ±0.20	5.10 ±0.20	7.00 ±0.20	9.40 ±0.20	4.60 ±0.15	2.70 ±0.20
EER25/21	25.80 ±0.40	21.40 ±0.30	7.50 ±0.20	20.20 ±0.40	7.50 ±0.15	15.20 ±0.40
EER28/20	28.50 ±0.50	20.00 ±0.30	11.40 ±0.25	21.40 <sub>min</sub>	9.90 ±0.25	12.80 +0.50/-0
EER28/28	28.50 ±0.60	28.00 ±0.50	11.40 ±0.30	21.20 <sub>min</sub>	9.90 ±0.30	19.30 ±0.50
EER28/34	28.50 ±0.60	33.80 ±0.50	11.40 ±0.30	21.20 <sub>min</sub>	9.90 ±0.30	25.00 ±0.50
EER30/16	30.00 ±0.50	16.00 ±0.30	20.00 ±0.30	25.60 <sub>min</sub>	11.00 ±0.20	10.60 ±0.40
EER30/32	29.80 ±0.80	31.60 ±0.60	9.50 ±0.30	22.00 <sub>min</sub>	9.50 ±0.30	22.00 ±0.60
EER34/35	34.20 ±0.80	35.80 ±0.40	10.80 ±0.30	25.60 <sub>min</sub>	10.80 ±0.30	25.40 ±0.60
EER35/30	35.00 ±0.70	30.00 ±0.40	11.30 ±0.30	25.30 <sub>min</sub>	11.30 ±0.30	20.00 ±0.40
EER35/42	35.30 ±0.50	41.80 ±0.50	11.30 ±0.30	26.40 <sub>min</sub>	11.30 ±0.30	29.80 ±0.50
EER35/43	35.30 ±0.50	43.00 ±0.50	11.30 ±0.30	26.40 <sub>min</sub>	11.30 ±0.30	31.00 ±0.50
EER39/40	39.30 ±0.50	40.40 ±0.50	12.70 ±0.20	29.30 <sub>min</sub>	12.70 ±0.20	30.00 ±0.50
EER39/43	39.30 ±0.50	42.20 ±0.50	12.70 ±0.30	29.30 <sub>min</sub>	12.70 ±0.30	32.00 ±0.50
EER39/45	39.30 ±0.50	44.60 ±0.50	12.70 ±0.30	29.30 <sub>min</sub>	12.70 ±0.30	34.20 ±0.50
EER40/42	40.00 <sup>+0.80</sup> -0.50	42.60 ±0.40	15.00 ±0.20	30.70 <sub>min</sub>	14.00 ±0.25	30.60 ±0.40
EER40/45	40.00 ±0.50	44.80 ±0.50	13.30 ±0.30	29.00 <sub>min</sub>	13.30 ±0.30	30.80 ±0.50
EER42/15	42.00 ±0.80	43.80 ±0.50	14.80 ±0.20	30.40 <sub>min</sub>	14.80 ±0.20	31.80 ±0.60
EER42/42	42.00 <sup>+0.80</sup> -0.50	42.40 ±0.40	20.00 <sup>+0</sup> -0.80	31.80 <sub>min</sub>	17.30 ±0.25	30.00 <sup>+1.0</sup> -0.50
EER42/45	42.00 ±0.50	44.60 ±0.60	15.20 ±0.30	30.50 <sub>min</sub>	15.20 ±0.30	32.60 ±0.60
EER42/49	42.00 ±0.80	49.40 ±0.40	19.60 ±0.40	31.50 <sub>min</sub>	17.30 ±0.35	37.60 ±0.60
EER44/45	44.00 ±1.00	44.60 ±0.50	14.90 ±0.30	32.50 <sub>min</sub>	14.90 ±0.30	33.00 ±0.80
EER45/35	45.00 ±1.00	35.00 ±0.40	17.60 ±0.40	33.00 <sub>min</sub>	17.60 ±0.40	21.90 ±0.50
EER49/42	49.00 <sup>+0.70</sup> -0.50	42.00 <sup>+0.10</sup> -0.20	17.20 <sup>+0.20</sup> -0.40	33.60 <sub>min</sub>	17.20 <sup>+0.20</sup> -0.40	28.80 <sup>+0.80</sup> -0
EER49/50	48.70 ±1.00	49.40 ±0.40	16.30 ±0.40	36.10 <sub>min</sub>	16.30 ±0.40	36.20 ±0.80
EER49/54	49.00 ±0.80	54.00 ±0.50	17.20 ±0.30	36.40 <sub>min</sub>	17.20 ±0.30	37.00 ±0.60

## Core Set Parameters and Electrical Characteristics

AL-Value (nH/N<sup>2</sup> ±25%): 1kHz, 0.25V, 100Ts, 25±3°C

Type	Le (mm)	Ae (mm <sup>2</sup> )	C1 (mm <sup>-1</sup> )	Ve (mm <sup>3</sup> )	AL for Material				
					CY- MP2B	CY- MP2A	CY- HP5	CY- HP7	CY- HP10
EER28/20	49.5	81.0	0.6	4095.5	3550	3300	-	-	-
EER28/28	63.0	86.0	0.7	5418.0	3100	2850	-	-	-
EER28/34	74.4	85.4	0.9	6353.8	2650	2450	-	-	-
EER30/16	43.2	109	0.4	4708.8	5900	5450	-	-	-
EER30/32	70.7	76.2	0.9	5387.3	2400	2200	-	-	-
EER34/35	79.0	97.0	0.8	7663.0	3000	2750	-	-	-
EER35/30	70.3	107	0.7	7522.1	3100	2850	-	-	-
EER35/42	91.0	109	0.8	9919.0	2950	2700	-	-	-
EER35/43	93.0	109	0.9	10137	2700	2500	-	-	-
EER39/40	92.6	124	0.7	11482	2650	2400	-	-	-
EER39/43	97.4	124	0.8	12077	2600	2400	-	-	-
EER39/45	101.5	123	0.8	12484	2600	2400	-	-	-
EER40/42	96.3	158	0.6	15215	3750	3450	-	-	-
EER40/45	97.4	151	0.6	14707	3400	3150	-	-	-
EER42/15	98.8	172	0.6	16993	4500	4200	-	-	-
EER42/42	95.1	234	0.4	22253	5200	4800	-	-	-
EER42/45	100	183	0.5	18300	4050	3750	-	-	-
EER42/49	109	232	0.5	25288	4450	4150	-	-	-
EER44/45	104	173	0.6	17992	3500	3200	-	-	-
EER45/35	81.2	232	0.4	18838	6050	5560	-	-	-
EER49/42	100	227	0.4	2270	5200	4800	-	-	-
EER49/50	114	211	0.5	24054	4150	3800	-	-	-
EER49/54	118	241	0.5	28438	5700	5250	-	-	-

## EF Cores of Soft Ferrite

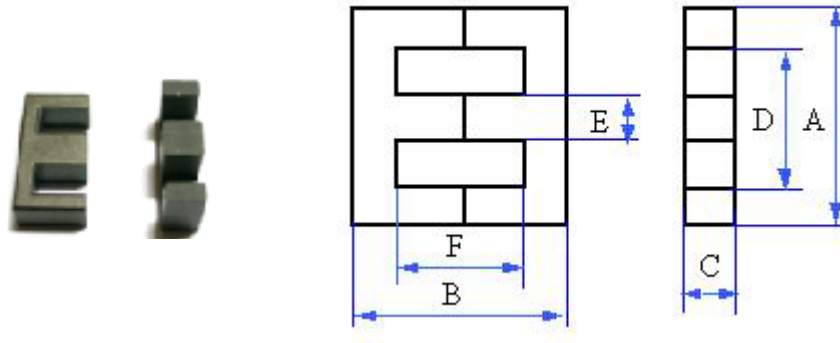

### Dimensions

Type	Dimensions (Unit: mm)					
	A	B	C	D	E	F
EF12.6	12.60 +0.50 <sub>-0.40</sub>	13.00 +0 <sub>-0.40</sub>	3.70 +0 <sub>-0.30</sub>	8.90 <sub>min</sub>	3.70 +0 <sub>-0.30</sub>	9.00 ±0.60
EF16	16.10 ±0.60	16.10 ±0.30	4.55 ±0.20	11.30 +0.3 <sub>-0</sub>	4.55 ±0.15	11.80 ±0.40
EF20	20.40 +0 <sub>-0.80</sub>	20.20 +0 <sub>-0.60</sub>	5.90 +0 <sub>-0.40</sub>	14.10 ±0.20	5.90 +0 <sub>-0.30</sub>	14.00 +0.60 <sub>-0</sub>
EF25	25.05 ±0.75	25.10 ±0.50	7.20 ±0.30	17.50 <sub>min</sub>	7.25 ±0.25	17.90 ±0.50
EF30	30.00 +0.80 <sub>-0.60&gt;</sub>	31.00 +0 <sub>-0.80</sub>	7.30 +0 <sub>-0.50</sub>	19.50 <sub>min</sub>	7.20 +0 <sub>-0.50</sub>	20.00 +0.80 <sub>-0.40</sub>

### Core Set Parameters and Electrical Characteristics

AL-Value (nH/N<sup>2</sup> ±25%): 1kHz, 0.25V, 100Ts, 25±3°C

Type	Le (mm)	Ae (mm <sup>2</sup> )	C1 (mm <sup>-1</sup> )	Ve (mm <sup>3</sup> )	AL for Material				
					CY-MP2B	CY-MP2A	CY-HP5	CY-HP7	CY-HP10
EF12.6	29.7	12.4	2.4	368.3	840	770	1350	1550	2600
EF16/11	37.7	19.5	1.9	735.2	1100	1000	2000	2400	3550
EF20/12	46.1	32.2	1.4	1484.4	1600	1500	2800	3350	4850
EF25	57.8	41.8	1.1	2994	2100	1900	4000	4550	6500
EF30	65.4	60.0	1.1	3924	2000	1850	-	-	-

## EFD Cores of Soft Ferrite

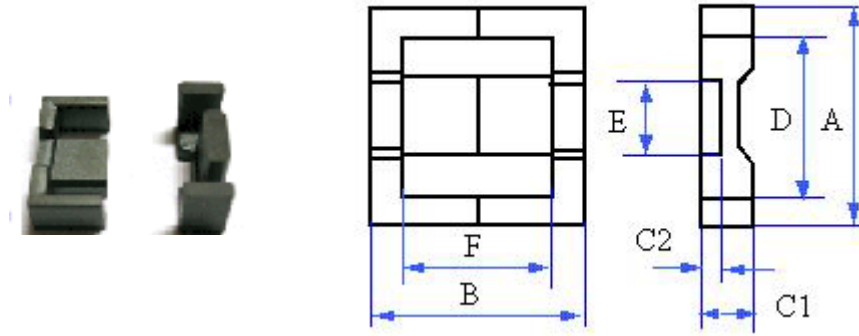

### Dimensions

Type	Dimensions (mm)							weight (g)
	A	B	C1	C2	D	E	F	
EFD10	10.5 ±0.3	5.2 ±0.2	2.7 ±0.1	1.45 ±0.05	7.65 ±0.25	4.55 ±0.15	7.5 ±0.3	0.9
EFD12	12.0 ±0.3	12.0 ±0.3	4.2 ±0.15	2.2 ±0.1	9.2 ±0.3	4.5 ±0.15	9.4 ±0.5	1.14
EFD12.5	12.5 ±0.3	12.4 ±0.2	3.5 ±0.1	2.0 ±0.1	9.0 ±0.25	5.4 ±0.15	9.1 ±0.3	1.15
EFD13	13.2 ±0.3	13.4 ±0.4	4.5 ±0.2	2.1 ±0.15	10.9 ±0.3	5.1 ±0.2	9.2 ±0.5	1.8
EFD14	13.9 ±0.3	17.2 ±0.4	3.3 ±0.2	1.6 ±0.1	10.45 ±0.25	5.6 ±0.15	13.1 ±0.5	2.0
EFD15A	14.8 ±0.6	18.0 ±0.4	6.8 ±0.2	4.6 ±0.2	11.1 ±0.3	5.6 ±0.2	12.0 ±0.5	5.3
EFD15	15.00 ±0.40	15.00 ±0.30	4.65 ±0.15	2.40 ±0.10	11.00 ±0.35	5.30 ±0.15	11.00 ±0.35	2.9
EFD16	16.4 ±0.3	18.0 ±0.4	4.5 ±0.3	2.4 ±0.1	12.3 <sub>min</sub>	6.7 ±0.15	14.6 ±0.4	3.2
EFD17	16.9 ±0.4	14.9 ±0.3	5.5 ±0.15	2.9 ±0.1	12.8 <sub>min</sub>	7.3 ±0.15	10.9 ±0.3	-
EFD20	20.0 ±0.55	20.0 ±0.5	6.65 ±0.2	3.6 ±0.2	15.4 ±0.2	8.9 ±0.2	15.4 ±0.5	7.4
EFD25	25.0 ±0.65	25.0 ±0.5	9.1 ±0.2	5.2 ±0.25	18.7 ±0.6	11.4 ±0.2	18.6 ±0.5	16.6
EFD28	28.4 ±0.4	28.2 ±0.4	11.1 ±0.2	6.5 ±0.15	21.8 <sub>min</sub>	12.7 ±0.2	19.1 ±0.5	19
EFD30	30.0 ±0.8	30.0 ±0.5	9.1 ±0.3	4.9 ±0.15	22.4 ±0.75	14.6 ±0.3	22.4 ±0.5	24

### Core Set Parameters and Electrical Characteristics

AL-Value (nH/N<sup>2</sup> ±25%): 1kHz, 0.25V, 100Ts, 25±3°C

Type	Le (mm)	Ae (mm <sup>2</sup> )	C1 (mm <sup>-1</sup> )	Ve (mm <sup>3</sup> )	AL for Material				
					CY-MP2B	CY-MP2A	CY-HP5	CY-HP7	CY-HP10
EFD13	29.5	9.80	3.01	289	-	750	-	-	-
EFD15	34.0	15.0	2.27	510	-	850	-	-	-
EFD16	32.6	17.4	1.87	567	-	940	-	-	-
EFD17	34.9	21.9	1.59	764	-	1260	-	-	-

## EI Cores of Soft Ferrite

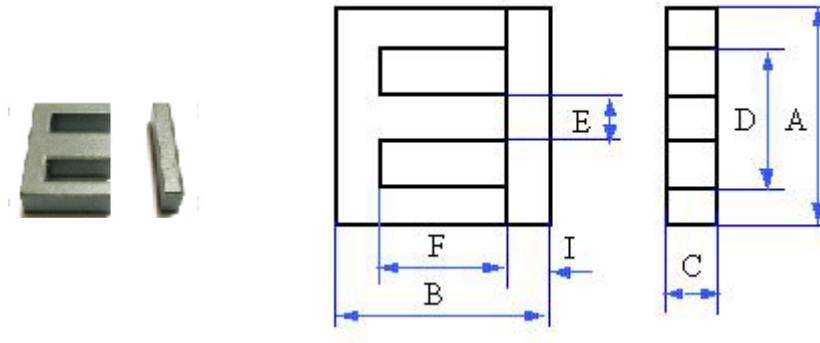

### Dimensions

Type	Dimensions (Unit: mm)						
	A	B	C	D	E	F	I
EI12.5	12.5 ±0.3	8.9 ±0.35	5.0 ±0.2	9.4 ±0.3	2.4 ±0.2	5.1 ±0.2	1.5 ±0.15
EI16	16.0 ±0.3	14.7 ±0.3	4.8 ±0.2	12.1 ±0.3	4.0 ±0.2	10.8 ±0.2	2.0 ±0.2
EI19	19.2 ±0.4	16.0 ±0.3	4.85 ±0.25	14.0 <sub>min</sub>	4.85 ±0.25	11.3 ±0.3	2.4 ±0.2
EI20	20.0 ±0.3	16.0 ±0.4	5.0 ±0.2	14.3 <sub>min</sub>	4.6 ±0.2	11.2 ±0.2	2.3 ±0.2
EI22A	22.0 ±0.4	19.0 ±0.5	5.8 ±0.3	16.0 ±0.4	5.8 ±0.3	11.0 ±0.3	4.0 ±0.3
EI22B	22.0 ±0.4	19.1 ±0.5	5.8 ±0.3	16.0 ±0.4	5.8 ±0.3	10.6 ±0.3	4.5 ±0.3
EI25	25.4 ±0.5	19.0 ±0.5	6.35 ±0.2	18.7 ±0.4	6.35 ±0.3	12.8 ±0.3	3.2 ±0.2
EI25A	25.4 ±0.5	19.3 ±0.5	6.55 ±0.25	18.6 <sub>min</sub>	6.6 ±0.3	13.2 ±0.3	3.0 ±0.2
EI26	26.5 ±0.5	20.8 ±0.5	8.0 ±0.3	18.5 <sub>min</sub>	7.0 ±0.3	13.5 ±0.3	3.75 ±0.25
EI28A	28.0 ±0.6	21.0 ±0.3	10.75 ±0.25	18.6 <sub>min</sub>	7.2 ±0.3	12.8 ±0.3	3.5 ±0.3
EI28B	28.0 ±0.5	20.5 ±0.5	10.7 ±0.3	19.0 ±0.4	7.2 ±0.3	12.5 ±0.3	3.5 ±0.2
EI28C	28.15 ±0.45	25.8 ±0.3	10.4 ±0.3	19.9 <sub>min</sub>	7.75 ±0.25	17.75 ±0.25	4.0 ±0.2
EI30	30.6 ±0.4	27.0 ±0.4	10.7 ±0.3	20.6 ±0.4	10.7 ±0.3	16.5 ±0.3	5.5 ±0.2
EI33	33.0 ±0.5	28.9 ±0.5	12.7 ±0.3	23.6 <sub>min</sub>	9.7 ±0.2	19.2 ±0.3	5.2 ±0.2
EI35A	35.0 ±0.5	29.7 ±0.5	10.0 ±0.3	24.6 <sub>min</sub>	10.0 ±0.3	18.2 ±0.4	5.5 ±0.2
EI35B	35.0 ±0.5	29.7 ±0.5	11.75 ±0.25	24.6 <sub>min</sub>	10.3 ±0.4	18.2 ±0.3	5.5 ±0.2
EI40A	40.0 ±0.7	34.0 ±0.5	11.75 ±0.25	26.8 <sub>min</sub>	11.75 ±0.25	21.35 ±0.35	6.7 ±0.3
EI40B	40.0 ±0.5	35.0 ±0.5	11.7 ±0.3	28.0 ±0.5	11.7 ±0.3	20.5 ±0.3	7.5 ±0.2
EI50	50.0 ±1.2	42.3 ±0.8	14.8 ±0.6	34.0 <sub>min</sub>	14.5 ±0.6	24.8 ±0.4	9.0 ±0.4
EI60	60.0 ±1.2	44.4 ±0.4	15.8 ±0.5	44.5 <sub>min</sub>	15.8 ±0.5	27.5 ±0.4	8.5 ±0.3
EI70	70.0 ±1.5	56.0 ±1.0	19.5 ±0.5	50.0 ±0.5	19.5 ±0.5	35.5 ±0.5	10.5 ±0.5

## Core Set Parameters and Electrical Characteristics

AL-Value (nH/N<sup>2</sup> ±25%): 1kHz, 0.25V, 100Ts, 25±3°C

Type	Le (mm)	Ae (mm <sup>2</sup> )	C1 (mm <sup>-1</sup> )	Ve (mm <sup>3</sup> )	AL for Material					weight (g)
					CY-MP3	CY-MP2B	CY-MP2A	CY-HP5	CY-HP7	
EI12.5	20.6	14.4	1.44	298	1300	1200	1100	-	-	1.9
EI16	35.9	18.8	1.9	674.9	-	1300	1200	1950	2250	3.3
EI19	39.1	26.3	1.5	1029	1600	1200	1200	-	-	5.6
EI20	39.2	23.3	1.7	913.4	-	1400	1300	2400	2750	-
EI22A	42.5	37.0	1.1	1572.5	2300	1900	1800	3200	3900	9.8
EI22B	39.3	42.0	0.94	1651	2300	2000	1900	3200	3900	9.8
EI25	48.6	39.7	1.2	1929.4	2100	1950	1800	3500	4300	9.8
EI25A	18.5	44.3	1.1	2145	2100	1800	1800	-	-	9.8
EI26	50.2	60.0	0.8	3012	2800	2600	2500	-	-	12
EI28A	49.3	89.5	0.55	4399	4500	3900	3700	-	-	22
EI28B	49.5	84.4	0.6	4177.8	4500	4300	3950	7000	8400	22
EI28C	60.0	85.9	0.7	5154	4000	3300	3000	-	-	23
EI30	58.8	109	0.5	6409.2	4900	4000	3700	-	-	34
EI33	67.1	118	0.6	7917.8	4500	4200	4000	-	-	41
EI35A	68.0	122	0.6	8296.0	4200	3500	3200	-	-	36
EI35B	66.9	102	0.7	6823.8	4400	3700	3400	-	-	43
EI40A	76.5	150	0.5	11534	5500	4700	4300	-	-	60
EI40B	77.4	147	0.5	11377	5500	4500	4200	-	-	60
EI50	94.1	231	0.4	21759	7000	5800	5400	-	-	115
EI60	111.8	272	0.4	30454	6400	5600	5200	-	-	139

## EPC Cores of Soft Ferrite

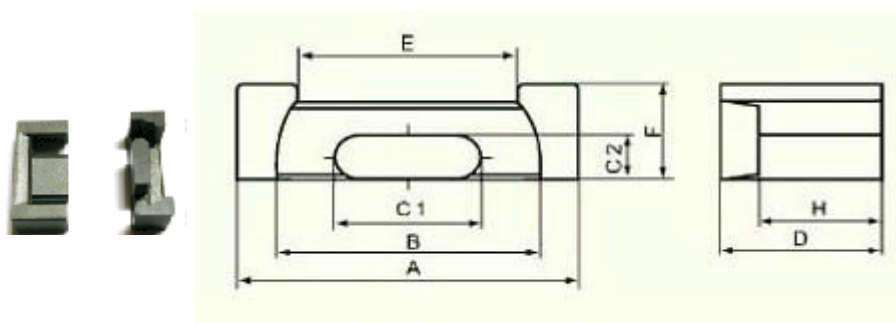

## Dimensions

Type	Dimensions (Unit: mm)								Weight (g)
	A	B	C1	C2	D	E	F	H	
EPC10	10.0 ±0.2	7.6 <sub>min</sub>	5.0 ±0.1	1.9 ±0.1	4.05 ±0.1	5.3 <sub>min</sub>	3.4 ±0.1	8.65 ±0.1	1.1
EPC13	13.3 ±0.3	10.5 <sub>min</sub>	5.6 ±0.15	2.05 ±0.1	6.6 ±0.2	8.3 <sub>min</sub>	4.6 ±0.15	4.5 ±0.2	2.1
EPC13A	13.0 ±0.25	10.2 <sub>min</sub>	4.8 ±0.15	2.2 ±0.1	7.5 ±0.25	8.9 <sub>min</sub>	4.0 ±0.15	5.5 ±0.2	2.1
EPC14	13.75 ±0.25	9.66 <sub>min</sub>	6.2 ±0.1	2.75 ±0.2	7.3 ±0.2	7.64 <sub>min</sub>	4.68 ±0.15	4.55 ±0.15	3.15
EPC14A	13.75 ±0.25	9.66 <sub>min</sub>	6.2 ±0.1	5.15 ±0.2	6.85 ±0.15	7.64 <sub>min</sub>	6.68 ±0.15	4.55 ±0.15	4.68
EPC17	16.8 ±0.3	13.5 <sub>min</sub>	7.5 ±0.15	2.75 ±0.2	7.3 ±0.2	11.1 <sub>min</sub>	5.7 ±0.2	5.5 ±0.2	3.8
EPC17A	17.6 ±0.3	14.3 <sub>min</sub>	7.7 ±0.15	2.8 ±0.1	8.55 ±0.2	11.5 <sub>min</sub>	6.0 ±0.15	6.05 ±0.2	3.5
EPC19	19.1 ±0.5	15.8 <sub>min</sub>	8.5 ±0.15	2.5 ±0.1	9.75 ±0.2	13.1 <sub>min</sub>	6.0 ±0.15	7.25 ±0.2	5.3
EPC19A	19.0 ±0.3	14.5 ±0.25	8.0 ±0.2	2.5 ±0.1	10.8 ±0.2	12.5 ±0.25	5.0 ±0.15	8.25 ±0.15	5.5
EPC19B	19.5 ±0.4	15.3 <sub>min</sub>	10.1 ±0.2	2.05 ±0.15	12.3 ±0.25	14.3 <sub>min</sub>	4.1 ±0.15	9.2 ±0.25	5.8
EPC20	20.3 ±0.3	15.1 ±0.25	9.0 ±0.2	3.1 ±0.1	8.8 ±0.2	13.0 ±0.25	5.6 ±0.15	6.3 ±0.15	5.7
EPC25	25.1 ±0.5	20.65 <sub>min</sub>	11.5 ±0.2	4.0 ±0.1	12.5 ±0.2	17.1 <sub>min</sub>	8.0 ±0.2	9.0 ±0.3	13.0
EPC27	27.1 ±0.5	21.6 <sub>min</sub>	13.0 ±0.3	4.0 ±0.1	16.0 ±0.2	18.5 <sub>min</sub>	8.0 ±0.2	12.0 ±0.3	18.0
EPC30	30.1 ±0.5	23.6 <sub>min</sub>	15.0 ±0.3	4.0 ±0.1	17.5 ±0.2	20.0 <sub>min</sub>	8.0 ±0.2	13.0 ±0.3	23.0

## Core Set Parameters and Electrical Characteristics

AL-Value (nH/N<sup>2</sup> ±25%): 1kHz, 0.25V, 100Ts, 25±3°C

Type	Le (mm)	Ae (mm <sup>2</sup> )	C1 (mm <sup>-1</sup> )	Ve (mm <sup>3</sup> )	AL for Material				
					CY-MP2B	CY-MP2A	CY-HP5	CY-HP7	CY-HP10
EPC13	30.6	12.5	2.4	382.5	900	850	-	-	-
EPC17	37.6	22.8	1.6	857.3	1350	1250	-	-	-
EPC17A	40.2	22.8	1.8	916.6	1250	1150	-	-	-

## EP Cores of Soft Ferrite

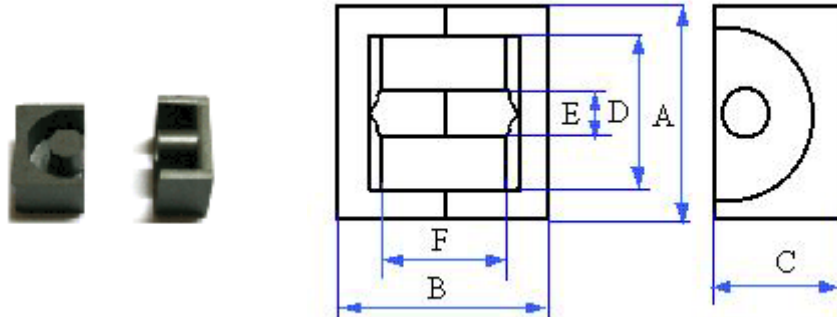

### Dimensions

Type	Dimensions (Unit: mm)						Weight (g)
	A	B	C	D	E	F	
EP7	9.2 ±0.2	7.4 ±0.2	6.35 ±0.15	7.2 <sub>min</sub>	3.3 ±0.1	5.2 ±0.20	1.4
EP10	11.5 ±0.3	10.2 ±0.2	7.65 ±0.2	9.2 <sub>min</sub>	3.3 ±0.15	7.4 ±0.2	2.8
EP13	12.5 ±0.3	13.0 ±0.3	8.8 ±0.2	9.7 <sub>min</sub>	4.4 ±0.2	9.2 ±0.2	4.9
EP17	18.0 ±0.4	16.8 ±0.4	11.0 ±0.25	11.6 <sub>min</sub>	5.7 ±0.2	11.3 ±0.3	5.2 ±0.2
EP20	20.0 ±0.5	21.4 ±0.4	15.5 ±0.4	16.1 <sub>min</sub>	8.8 ±0.3	14.4 ±0.4	28

### Core Set Parameters and Electrical Characteristics

AL-Value (nH/N<sup>2</sup> ±25%): 1kHz, 0.25V, 100Ts, 25±3°C

Type	Le (mm)	Ae (mm <sup>2</sup> )	C1 (mm <sup>-1</sup> )	Ve (mm <sup>3</sup> )	AL for Material				
					CY-MP2B	CY-MP2A	CY-HP5	CY-HP7	CY-HP10
EP7	15.7	10.3	1.5	161.7	-	1050	-	-	5500
EP10	19.2	11.3	1.7	217.0	-	1050	-	-	5040
EP13	24.2	19.5	1.2	471.9	-	1550	-	-	7350
EP17	28.5	33.9	0.8	966.2	-	2300	-	-	13000
EP20	39.8	79	0.508	3120	4000	3800	-	-	-

## ET/UT Cores of Soft Ferrite

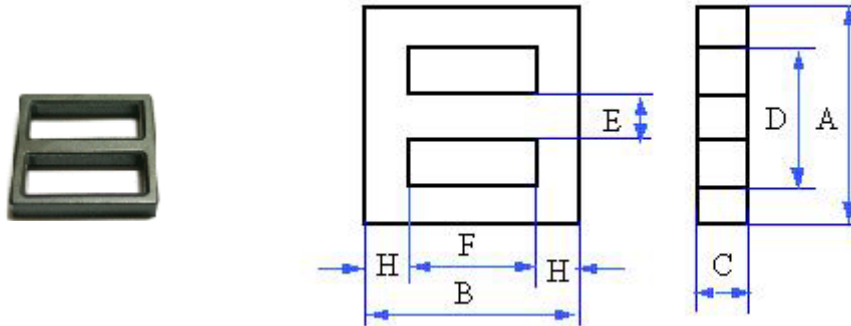

### Dimensions

Type	Dimensions (Unit: mm)							Weight (g)
	A	B	C	D	E	F	H	
ET20/20	20.1 ±0.4	20.1 ±0.4	4.4 ±0.2	15.7 <sub>min</sub>	4.0 ±0.2	15.7 <sub>min</sub>	2.0 ±0.2	4.5
ET24/24	24.2 ±0.5	24.2 ±0.3	4.0 ±0.3	19.0 <sub>min</sub>	4.0 ±0.2	19.0 <sub>min</sub>	2.4 ±0.15	5.6
ET25/25	25.5 ±0.5	25.5 ±0.3	5.0 ±0.3	19.2 <sub>min</sub>	5.0 ±0.3	19.2 <sub>min</sub>	3.15 ±0.15	8.5
ET28/28	28.7 ±0.5	28.7 ±0.3	5.0 ±0.3	22.2 <sub>min</sub>	5.0 ±0.2	22.2 <sub>min</sub>	2.9 ±0.15	10.5
ET35/35	35.3 ±0.6	35.3 ±0.6	7.5 ±0.3	26.5 <sub>min</sub>	7.5 ±0.3	26.5 <sub>min</sub>	4.0 ±0.2	26

### Core Set Parameters and Electrical Characteristics

AL-Value (nH/N<sup>2</sup> ±25%): 1kHz, 0.25V, 100Ts, 25±3°C

Type	Le (mm)	Ae (mm <sup>2</sup> )	C1 (mm <sup>-1</sup> )	Ve (mm <sup>3</sup> )	AL for Material				
					CY-MP2B	CY-MP2A	CY-HP5	CY-HP7	CY-HP10
ET20/20	50.5	17.2	2.9	868.6	-	-	2150	3000	4300
ET24/24	60.8	17.5	3.5	1064.0	-	-	1800	2500	3600
ET25/25	62.35	27.6	2.3	1721	-	-	-	3200	3820
ET28/28	71.1	26.8	2.7	1891.3	-	-	2350	3350	4700
ET35/35	86.8	57.9	1.5	5014.1	-	-	4200	5950	8400

## ETS/FT Cores of Soft Ferrite

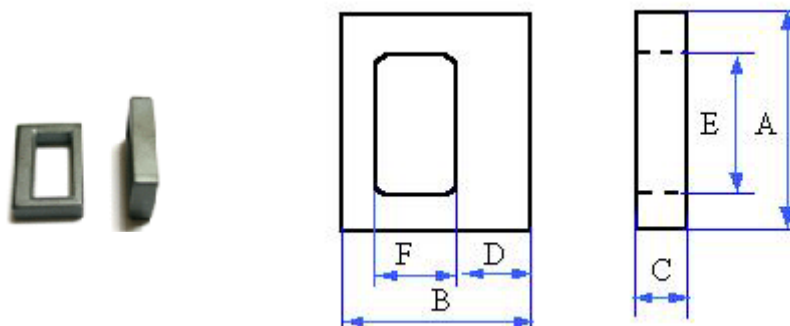

### Dimensions

Type	Dimensions (Unit: mm)						Weight (g)
	A	B	C	D	E	F	
FT18	17.8 ±0.3	15.1 ±0.3	4.0 ±0.2	4.5 ±0.2	12.0 ±0.2	6.9 ±0.2	3.6
FT20	20.6 ±0.3	14.1 ±0.3	4.6 ±0.2	4.2 ±0.2	16.0 ±0.3	7.6 ±0.25	3.7
FT21	21.2 ±0.3	15.8 ±0.3	4.5 ±0.3	4.0 ±0.2	15.6 ±0.3	7.0 ±0.3	3.7
FT21.5	21.5 ±0.3	15.8 ±0.3	4.5 ±0.3	4.0 ±0.2	15.6 ±0.3	7.0 ±0.3	3.7

### Core Set Parameters and Electrical Characteristics

AL-Value (nH/N<sup>2</sup> ±25%): 1kHz, 0.25V, 100Ts, 25±3°C

Type	Le (mm)	Ae (mm <sup>2</sup> )	C1 (mm <sup>-1</sup> )	Ve (mm <sup>3</sup> )	AL for Material				
					CY-MP2B	CY-MP2A	CY-HP5	CY-HP7	CY-HP10
FT18	59.8	14.0	4.3	837.2	-	-	-	1430	2040
FT20	53.0	13.0	4.11	688	-	-	1550	2140	3000
FT21	66.6	13.5	4.9	899.1	-	-	-	2300	2700
FT21.5	68.3	16.5	4.1	1129.5	-	-	-	2300	2700

## OR Cores of Soft Ferrite

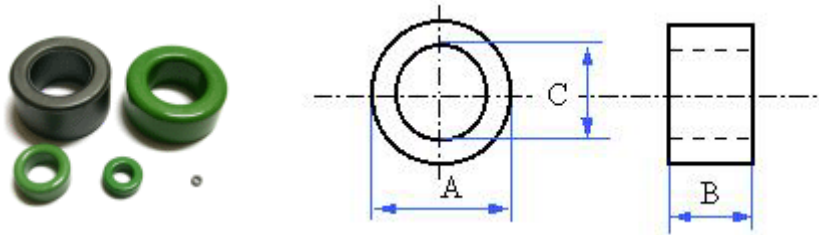

### Dimensions

Type	Dimensions (Unit: mm)		
	A	B	C
OR2.45x1.27x1.27	2.45 ±0.15	1.27 ±0.15	1.27 ±0.15
OR3.5x1.3x1.8	3.45 ±0.15	1.30 ±0.15	1.75 ±0.15
OR3.5x2.2x1.8	3.45 ±0.15	2.20 ±0.15	1.75 ±0.15
OR3.94x2.54x2.24	3.94 ±0.15	2.54 ±0.15	2.24 ±0.15
OR4x1x2	4.00 ±0.30	1.00 ±0.20	2.00 ±0.30
OR4x2x2	4.00 ±0.20	2.00 ±0.20	2.00 ±0.20
OR4x2.54x2	4.00 ±0.20	2.54 ±0.20	2.00 ±0.20
OR4.83x1.27x2.29	4.83 ±0.12	1.27 ±0.15	2.29 ±0.15
OR4.83x2.54x2.29	4.83 ±0.15	2.54 ±0.12	2.29 ±0.15
OR5.84x1.52x3.05	5.84 ±0.15	1.52 ±0.15	3.05 ±0.15
OR5.84x3.05x3.05	5.84 ±0.15	3.05 ±0.15	3.05 ±0.15
OR5.84x3.2x3.05	5.84 ±0.15	3.20 ±0.15	3.05 ±0.15
OR6x2x3	6.00 ±0.30	2.00 ±0.30	3.00 ±0.30
OR6x3x3	6.00 ±0.30	3.00 ±0.20	3.00 ±0.30
OR8x2x4	8.00 ±0.30	2.00 ±0.20	4.00 ±0.30
OR9x3x5	9.00 ±0.30	3.00 ±0.30	5.00 ±0.30
OR10x4x6	10.10 ±0.30	4.00 ±0.30	6.00 ±0.30
OR10x5x6	10.10 ±0.30	5.00 ±0.30	6.00 ±0.30
OR10x6x6	10.10 ±0.30	6.00 ±0.30	6.00 ±0.30
OR12x4x6	12.70 ±0.40	4.00 ±0.30	6.00 ±0.30
OR12.7x4.5x7.92	12.70 ±0.40	4.50 ±0.30	7.92 ±0.30
OR12.7x4.7x7.92	12.70 ±0.40	4.70 ±0.30	7.92 ±0.30
OR12.7x4.9x7.92	12.70 ±0.40	4.70 ±0.30	7.92 ±0.30
OR12.7x5.2x7.92	12.70 ±0.40	5.20 ±0.30	7.92 ±0.30
OR12.7x6.3x7.92	12.70 ±0.40	6.35 ±0.30	7.92 ±0.30
OR12.7x7x7.92	12.70 ±0.40	7.00 ±0.30	7.92 ±0.30
OR14x3x8	14.0 ±0.40	3.00 ±0.30	8.00 ±0.30
OR14x7x8	14.0 ±0.40	7.00 ±0.30	8.00 ±0.30
OR14x9x8	14.0 ±0.40	9.00 ±0.30	8.00 ±0.30
OR14x5x9	14.0 ±0.40	5.00 ±0.30	9.00 ±0.30
OR16x5x9	16.0 ±0.40	5.00 ±0.30	9.00 ±0.30
OR16x8x12	15.80 ±0.40	8.00 ±0.30	11.90 ±0.30
OR18x7x10	18.00 ±0.40	7.00 ±0.30	10.00 ±0.30
OR18x8x10	18.00 ±0.40	8.00 ±0.30	10.00 ±0.30
OR18x10x10	18.00 ±0.40	10.00 ±0.30	10.00 ±0.30

Type	Dimensions (Unit: mm)		
	A	B	C
OR18x6x12	18.00 ±0.40	6.00 ±0.20	11.90 ±0.30
OR20x10x10	20.00 ±0.40	10.00 ±0.30	10.00 ±0.30
OR22.1x6.35x13.7	22.10 ±0.40	6.35 ±0.25	13.70 ±0.30
OR22.1x8x13.7	22.10 ±0.40	8.00 ±0.30	13.70 ±0.30
OR22.1x9x13.7	22.10 ±0.40	9.00 ±0.30	13.70 ±0.30
OR22.1x10x13.7	22.10 ±0.40	10.00 ±0.30	13.70 ±0.30
OR22.1x12.7x13.7	22.10 ±0.40	12.70 ±0.30	13.70 ±0.30
OR25x8x15	25.00 ±0.40	8.00 ±0.30	15.00 ±0.40
OR25x10x15	25.00 ±0.40	10.00 ±0.30	15.00 ±0.40
OR25x12x15	25.00 ±0.40	12.00 ±0.30	15.00 ±0.40
OR25x15x15	25.00 ±0.40	15.00 ±0.30	15.00 ±0.40
OR26x15x16	26.00 ±0.40	15.00 ±0.30	16.00 ±0.40
OR28x13x16	28.00 ±0.40	13.00 ±0.30	16.00 ±0.40
OR29x15.2x19	29.00 ±0.40	19.00 ±0.30	15.20 ±0.30
OR31x7x19	31.00 ±0.50	7.00 ±0.30	19.00 ±0.50
OR31x13x19	31.00 ±0.50	13.00 ±0.40	19.00 ±0.50
OR32x8x11	32.00 ±0.40	7.60 ±0.30	10.60 ±0.30
OR36x15x23	36.00 ±0.50	15.00 ±0.40	23.00 ±0.50
OR36x15x25	36.00 ±0.50	15.00 ±0.40	25.00 ±0.50
OR44.5x13x30	44.50 ±0.80	13.00 ±0.40	30.00 ±0.40
OR49x19x31.8	49.00 ±0.80	19.00 ±0.50	31.80 ±0.40
OR60x12.5x40	60.00 ±0.80	12.50 ±0.40	40.00 ±0.60
OR60x25x40	60.00 ±0.80	25.00 ±0.60	40.00 ±0.60

## Core Set Parameters and Electrical Characteristics

AL-Value (nH/N<sup>2</sup> ±25%): 1kHz, 0.25V, 100Ts, 25±3°C

Type	Le (mm)	Ae (mm <sup>2</sup> )	C1 (mm <sup>-1</sup> )	Ve (mm <sup>3</sup> )	AL for Material				
					CY-MP2B	CY-MP2A	CY-HP5	CY-HP7	CY-HP10
OR2.45x1.27x1.27	5.98	0.80	7.47	4.82	490	440	880	1230	1760
OR3.5x1.3x1.8	8.16	1.10	7.54	9.02	460	410	830	1160	1660
OR3.5x2.2x1.8	8.16	1.87	3.83	15.27	780	690	1400	1960	2800
OR3.94x2.54x2.24	9.70	2.15	4.51	20.90	830	740	1475	2065	2950
OR4x1x2	9.42	1.00	8.71	9.42	370	330	720	920	1300
OR4x2x2	9.42	2.00	4.71	18.84	710	640	1400	2000	2500
OR4x2.54x2	9.42	2.54	3.70	23.93	985	880	1760	2460	3520
OR4.83x1.27x2.29	11.18	1.61	6.93	18.03	530	470	940	1320	1890
OR4.83x2.54x2.29	11.18	3.22	3.31	36.07	1060	950	1900	2660	3800
OR5.84x1.52x3.05	13.96	2.12	6.58	29.61	550	490	980	1370	1960
OR5.84x3.05x3.05	13.96	4.25	3.28	59.33	1110	990	1980	2770	3960
OR5.84x3.2x3.05	13.96	4.46	3.13	32.33	1140	1020	2040	2860	4080
OR6x2x3	14.13	3.00	4.65	42.41	740	660	1450	2200	2600
OR6x3x3	14.13	4.50	2.91	63.61	1120	1000	2200	2800	4000
OR6x2.15x4	15.70	2.15	7.30	33.70	480	430	870	1200	1740
OR7.62x4.8x3.18	16.90	10.65	1.59	180.7	2340	2090	4175	5845	8350

Type	Le (mm)	Ae (mm <sup>2</sup> )	C1 (mm <sup>-1</sup> )	Ve (mm <sup>3</sup> )	AL for Material				
					CY- MP2B	CY- MP2A	CY- HP5	CY- HP7	CY- HP10
OR8x2x4	18.84	4.00	4.71	75.39	770	690	1380	1940	2770
OR8x3x4	18.84	4.00	4.71	75.39	770	690	1380	1940	2770
OR8x4x4	18.84	8.00	2.36	150.79	1150	1380	2770	2880	5540
OR9x3x5	22.3	6.00	3.67	133	980	880	1760	2470	3520
OR9x4x5	22.3	8.0	2.20	223	1645	1175	2938	3290	4700
OR9x5x5	22.3	10.00	2.20	223	1645	1469	2938	4114	5877
OR9x5.5x5	22.3	11.00	2.00	245	1810	1616	3232	4525	6465
OR9x7x5	22.3	14.00	1.57	312	2304	2075	4114	5760	8229
OR9.53x3.2x4.75	22.43	7.64	2.96	171	1240	1110	2230	3210	4450
OR9.53x4.7x4.75	22.43	11.23	1.99	251.9	1830	1630	3270	4580	6540
OR9.53x4.8x4.75	22.43	11.47	1.95	257.3	1870	1670	3340	4680	6680
OR9.53x6.3x4.75	22.43	15.05	1.49	337.74	2450	2190	4380	6140	8770
OR16x5x9	39.26	17.50	2.29	687	1460	1300	2600	3650	5210
OR19x8x12	42.9	15.4	2.80	660.7	1130	1030	2270	3170	4500
OR18x7x10	43.8	28.00	1.57	1231	2300	2054	4110	5760	8230
OR18x8x10	43.98	32.00	1.34	1407	2630	2350	4700	6580	9400
OR18x10x10	43.98	40.00	1.10	1759	3290	2940	5880	8230	11750
OR18x6x12	47.12	18.00	2.62	848.22	1360	1210	2430	3400	4860
OR20x10x10	43.6	48.00	0.9	2092.8	3440	3160	6900	9660	13760
OR22.1x6.35x13.7	54.1	26.1	2.1	1412	1510	1390	3030	4520	6040
OR22.1x8x13.7	54.1	32.00	1.44	1809	2020	1804	3620	5060	7230
OR22.1x9x13.7	54.1	36.00	1.58	2035	2278	2034	4070	5695	8135
OR22.1x10x13.7	54.1	40.00	1.41	2261	2530	2259	4520	6330	9040
OR22.1x12.7x13.7	54.1	52.2	1.0	2834.5	3020	2780	6030	8450	12000
OR25x8x15	60.2	40.00	1.57	2513	2290	2040	4090	5720	8200
OR25x10x15	60.2	48.9	1.2	2943.8	2250	2350	5100	7140	10200
OR25x12x15	60.12	60.00	1.05	3770	3432	3064	6130	8580	12260
OR25x15x15	60.2	75.00	0.48	4172	4290	3830	7660	10720	5330
OR26x15x16	63.5	73.5	0.9	4667.3	3650	3350	7270	10170	14500
OR28x13x16	65.6	75.9	0.9	4979	3650	3350	7270	10170	14500
OR29x15.2x19	73.2	74.9	0.98	5482.68	3210	2960	6430	9000	-
OR31x7x19	48.53	42.00	1.36	3298	1919	1713	3426	4797	6853
OR31x13x19	78353	72.00	1.10	5654	3280	2930	5870	8220	11740
OR32x8x11	55.0	73.5	0.75	4042.50	4200	3860	8400	11750	-
OR36x15x23	89.6	95.8	0.9	8583	3330	3060	6070	9330	133200
OR36x15x25	93.7	81.6	1.15	15633.75	2730	2520	5470	7660	-
OR44.5x13x30	114.0	93.0	1.23	10602	2560	2360	5130	7180	-
OR49x19x31.8	123.1	162.0	0.91	19942.20	4120	3790	8240	11540	-
OR60x25x40	152.8	246.6	0.62	37680.48	5070	4660	10140	14190	-

## PC Cores of Soft Ferrite

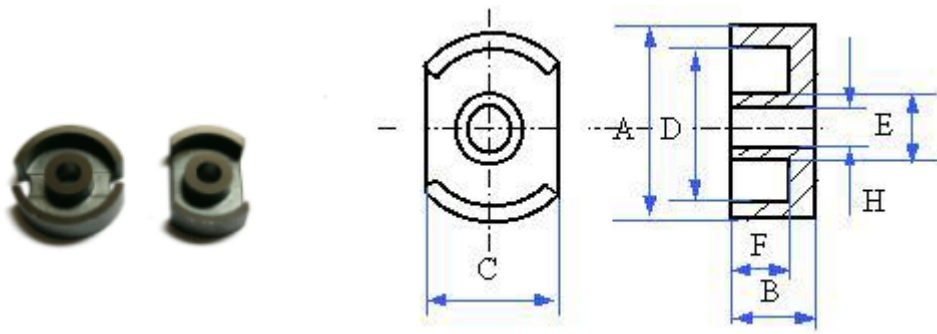

### Dimensions

Type	Dimensions (Unit: mm)						
	A	B	C	D	E	F	H
PC14/8	14.0 ±0.25	4.15 ±0.2	9.4 ±0.2	11.8 ±0.2	5.9 ±0.15	2.90 ±0.20	3.10 ±0.10

### Core Set Parameters and Electrical Characteristics

AL-Value (nH/N<sup>2</sup> ±25%): 1kHz, 0.25V, 100Ts, 25±3°C

Type	Le (mm)	Ae (mm <sup>2</sup> )	C1 (mm <sup>-1</sup> )	Ve (mm <sup>3</sup> )	AL for Material				
					CY-MP2B	CY-MP2A	CY-HP5	CY-HP7	CY-HP10
PC14/8	19.8	25.0	0.789	395	-	2400	-	-	5600

## P/POT Cores of Soft Ferrite



Material grade:  
CY-MP2 ~ CYMP4  
CY-HP5 ~ CY-HP10

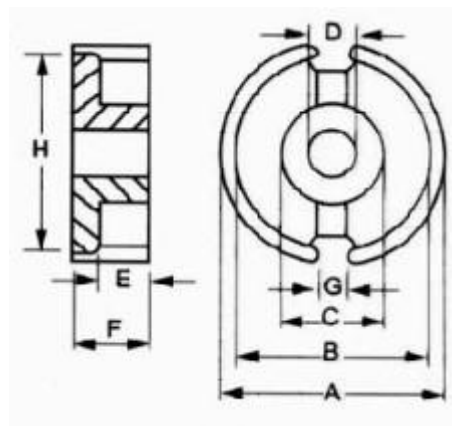

## Dimensions

Type	Dimensions (Unit: mm)							
	A	B	D	E	F	H	F	H
P14/8	13.95 ±0.45	11.8 ±0.4	5.9 ±0.3	3.05 ±0.15	2.95 ±0.15	4.20 ±0.10	3.2 ±0.9	10.4
	14.05 ±0.25	11.8 ±0.2	5.85 ±0.15	3.1 ±0.1	2.9 ±0.1	4.17 ±0.08	3.2 ±0.9	10.4
P18/11	18.0 ±0.6	15.05 ±0.45	7.5 ±0.3	3.05 ±0.15	3.75 ±0.15	5.4 ±0.10	3.55 ±0.85	14.0
	18.0 ±0.4	15.15 ±0.25	7.45 ±0.15	3.1 ±0.1	3.7 ±0.1	5.27 ±0.08	3.55 ±0.85	14.0
P22/13	21.6 ±0.6	18.2 ±0.6	9.2 ±0.3	4.45 ±0.25	4.75 ±0.15	6.8 ±0.10	3.7 ±0.7	16.5
	21.8 ±0.4	18.2 ±0.3	9.25 ±0.15	4.55 ±0.15	4.7 ±0.1	6.7 ±0.10	3.7 ±0.7	16.5
P26/16	25.45 ±0.75	21.6 ±0.6	11.3 ±0.4	5.45 ±0.25	5.7 ±0.2	8.1 ±0.2	3.7 ±0.7	20.0
	25.5 ±0.5	21.6 ±0.4	11.3 ±0.2	5.6 ±0.2	5.6 ±0.1	8.05 ±0.1	3.7 ±0.7	20.0
P30/19	30.0 ±0.8	25.35 ±0.75	13.25 ±0.45	5.45 ±0.25	6.7 ±0.2	9.55 ±0.15	4.4 ±0.9	23.0
	30.0 ±0.5	25.4 ±0.4	13.2 ±0.2	5.55 ±0.15	6.6 ±0.1	9.4 ±0.1	4.4 ±0.9	23.0
P36/22	35.55 ±0.95	30.4 ±0.9	15.85 ±0.45	5.45 ±0.25	7.5 ±0.2	10.95 ±0.15	4.8 ±0.8	27.2
	35.6 ±0.6	30.4 ±0.5	15.9 ±0.3	5.55 ±0.15	7.4 ±0.1	10.85 ±0.15	4.8 ±0.8	27.2

## PQ Cores of Soft Ferrite

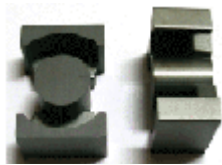

Material grade:  
CY-MP2 ~ CYMP4  
CY-HP5 ~ CY-HP10

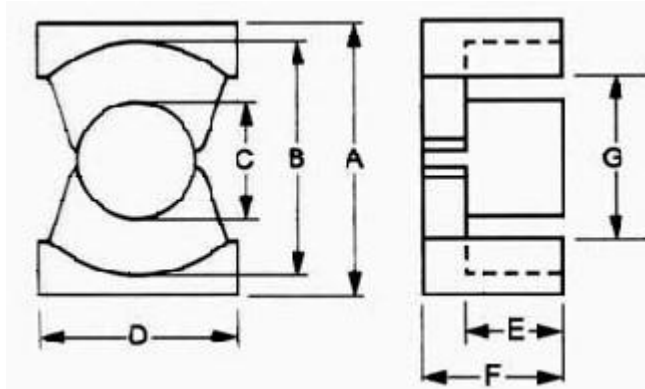

## Dimensions

Type	Dimensions (Unit: mm)							Weight(g)
	A	B	C	D	E	F	G	
PQ20/16	20.5 ±0.40	18.0 ±0.40	8.8 ±0.20	14.0 ±0.40	5.15 ±0.15	8.1 ±0.10	12.0	13
PQ20/20	20.5 ±0.40	18.0 ±0.40	8.8 ±0.20	14.0 ±0.40	7.15 ±0.15	10.1 ±0.10	12.0	15
PQ26/20	26.5 ±0.45	22.5 ±0.45	12.0 ±0.20	19.0 ±0.45	5.55 ±0.15	10.07 ±0.13	15.5	31
PQ26/25	26.5 ±0.45	22.5 ±0.45	12.0 ±0.20	19.0 ±0.45	8.05 ±0.15	12.37 ±0.13	15.5	36
PQ32/30	32.0 ±0.5	27.5 ±0.5	13.45 ±0.25	22.0 ±0.5	5.7 ±0.1	10.27 ±0.13	19.0	42
PQ32/20	32.0 ±0.5	27.5 ±0.5	13.45 ±0.25	22.0 ±0.5	10.45 ±0.15	15.17 ±0.13	19.0	55
PQ35/35	35.0 ±0.5	32.0 ±0.5	14.35 ±0.25	26.0 ±0.5	12.5 ±0.15	17.37 ±0.13	23.5	73
PQ40/40	40.9 ±0.9	37.0 ±0.6	14.9 ±0.3	28.0 ±0.5	14.75 ±0.15	19.87 ±0.13	27.5	95

## RH Cores of Soft Ferrite

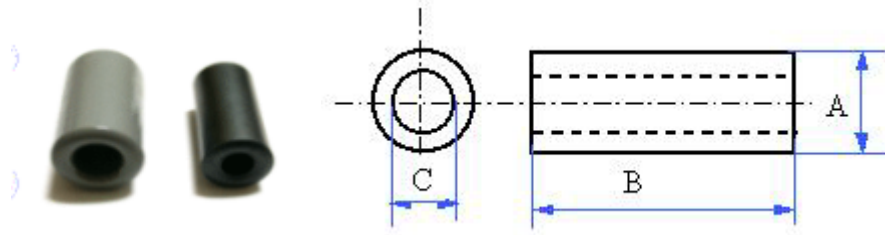

### Dimensions

Ordering Code	A (mm)	B (mm)	C (mm)	Ordering Code	A (mm)	B (mm)	C (mm)
RH3.5×3.5×0.8	3.5 ±0.20	3.5 ±0.20	0.8 ±0.15	RH3.5×4.7×0.8	3.5 ±0.20	4.7 ±0.20	0.8 ±0.15
RH3.5×3.5×1.2	3.5 ±0.20	4.7 ±0.20	1.2 ±0.15	RH3.5×5×1.3	3.5 ±0.20	5.0 ±0.20	1.3 ±0.15
RH3.5×6×1.2	3.5 ±0.20	6.0 ±0.20	1.2 ±0.15	RH3.5×10×1.5	3.5 ±0.20	10.0 ±0.30	1.5 ±0.15
RH4×5×1.2	4.0 ±0.20	5.0 ±0.20	1.2 ±0.15	RH4×10×2	4.0 ±0.20	10.0 ±0.30	2.0 ±0.15
RH4.5×20×2.4	4.5 ±0.20	20.0 ±0.50	2.4 ±0.25	RH6×10×3	6.0 ±0.30	10.0 ±0.40	3.0 ±0.25
RH6.8×14.2×4	6.8 ±0.30	14.2 ±0.40	4.0 ±0.25	RH7.5×30×4	7.5 ±0.30	30.0 ±0.80	4.0 ±0.25
RH8×10×5.5	8.0 ±0.30	10.0 ±0.30	5.5 ±0.30	RH8×14×4	8.0 ±0.30	14.0 ±0.40	4.0 ±0.25
RH8×15×5.5	8.0 ±0.30	15.0 ±0.40	5.5 ±0.30	RH9×16×5	9.0 ±0.30	16.0 ±0.50	5.0 ±0.30
RH9×20×5	9.0 ±0.30	20.0 ±0.50	5.0 ±0.30	RH9.5×10×5	9.5 ±0.30	10.0 ±0.40	5.0 ±0.30
RH9.5×12.7×5	9.5 ±0.30	12.7 ±0.40	5.0 ±0.30	RH9.5×14.5×5	9.5 ±0.30	14.5 ±0.40	5.0 ±0.30
RH9.5×14×6.5	9.5 ±0.30	14.0 ±0.40	6.5 ±0.30	RH9.5×20×5	9.5 ±0.30	20.0 ±0.50	5.0 ±0.30
RH9.5×20×6	9.5 ±0.30	20.0 ±0.50	6.0 ±0.30	RH9.8×20×4.7	9.8 ±0.30	20.0 ±0.50	4.7 ±0.30
RH10×14×6	10.0 ±0.30	14.0 ±0.40	6.0 ±0.30	RH10×20×6	10.0 ±0.30	20.0 ±0.50	6.0 ±0.30
RH10.5×14×5.6	10.5 ±0.30	14.0 ±0.50	5.6 ±0.30	RH10.5×20×5.6	10.5 ±0.30	20.0 ±0.50	5.6 ±0.30
RH11.6×18×5	11.6 ±0.30	18.0 ±0.50	5.0 ±0.30	RH12×15×7.3	12.0 ±0.40	15.0 ±0.50	7.3 ±0.30
RH12×20×5.6	12.0 ±0.40	20.0 ±0.40	5.6 ±0.30	RH12×20×6.5	12.0 ±0.40	20.0 ±0.40	6.5 ±0.30
RH12×28.5×5.6	12.0 ±0.40	28.5 ±0.70	5.6 ±0.30	RH12.2×23×7.9	12.2 ±0.40	23.0 ±0.40	7.9 ±0.30
RH12.7×13×7	12.7 ±0.40	13.0 ±0.50	7.0 ±0.30	RH12.7×15×7.3	12.7 ±0.40	15.0 ±0.50	7.3 ±0.30
RH13×18×5.5	13.0 ±0.40	18.0 ±0.50	5.5 ±0.30	RH13×18×8	13.0 ±0.40	18.0 ±0.50	8.0 ±0.30
RH13×20×7.2	13.0 ±0.40	20.0 ±0.50	7.2 ±0.30	RH13×29×5.5	13.0 ±0.40	29.0 ±0.70	5.5 ±0.30
RH14.2×23.5×6.35	14.2 ±0.40	23.5 ±0.50	6.35 ±0.30	RH14.2×23.5×8.1	14.2 ±0.40	23.5 ±0.50	8.1 ±0.40
RH14.2×15×6.35	14.2 ±0.40	15.0 ±0.40	6.35 ±0.30	RH14.2×28.5×4.5	14.2 ±0.40	28.5 ±0.70	4.5 ±0.30

Ordering Code	A (mm)	B (mm)	C (mm)	Ordering Code	A (mm)	B (mm)	C (mm)
RH14.2x20x6.35	14.2 ±0.40	20.0 ±0.50	6.35 ±0.30	RH14.2x28.5x6.35	14.2 ±0.40	28.5 ±0.70	6.35 ±0.30
RH14.2x28.5x6.5	14.2 ±0.40	28.5 ±0.70	6.5 ±0.30	RH14.2x28.5x7	14.2 ±0.40	28.5 ±0.70	7.0 ±0.30
RH14.2x28.5x8	14.2 ±0.40	28.5 ±0.70	8.0 ±0.30	RH14.2x28.5x9.3	14.2 ±0.40	28.5 ±0.70	9.3 ±0.30
RH15x15x7.2	15.0 ±0.40	15.0 ±0.50	7.2 ±0.30	RH15x18x7.2	15.0 ±0.40	18.0 ±0.50	7.2 ±0.30
RH15.65x28.5x7	15.65 ±0.40	28.5 ±0.70	7.0 ±0.30	RH15.65x28.5x8.5	15.65 ±0.40	28.5 ±0.70	8.5 ±0.30
RH16x17x4.3	16.0 ±0.50	17.0 ±0.50	4.3 ±0.30	RH16x17x9	16.0 ±0.50	17.0 ±0.50	9.0 ±0.40
RH16x17x9.3	16.0 ±0.50	17.0 ±0.50	9.3 ±0.40	RH16x28x9	16.0 ±0.50	28.0 ±0.70	9.0 ±0.40
RH17.5x28.5x8.3	17.5 ±0.50	28.5 ±0.70	8.3 ±0.40	RH17.5x28.5x9.5	17.5 ±0.50	28.5 ±0.70	9.5 ±0.40
RH17.5x28.5x10	17.5 ±0.50	28.5 ±0.70	10.0 ±0.40	RH17.5x28.5x10.7	17.5 ±0.50	28.5 ±0.70	10.7 ±0.40
RH18x20x10	18.0 ±0.50	20.0 ±0.50	10.0 ±0.40	RH18x20x11.2	18.0 ±0.50	20.0 ±0.50	11.2 ±0.40
RH18.2x28.5x9.7	18.2 ±0.50	28.5 ±0.70	9.7 ±0.40	RH18.2x28.5x12.8	18.2 ±0.50	28.5 ±0.70	12.8 ±0.40
RH18.4x28.5x10.2	18.4 ±0.50	28.5 ±0.70	10.2 ±0.40	RH20.5x28.5x13.5	20.5 ±0.50	28.5 ±0.70	13.5 ±0.40
RH25.9x28.5x12.7	25.9 ±0.60	28.5 ±0.70	12.7 ±0.40				

## RHW Cores of Soft Ferrite

RHW cores are produced for the automatic insertion into PC boards (Packaging: 5000 pcs per reel).

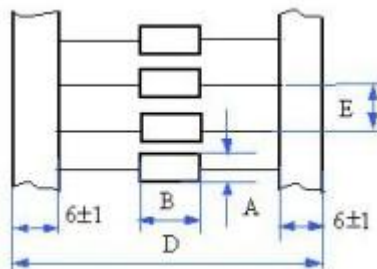

### Dimensions

Cores	A (mm)	B (mm)	D (mm);	E (mm)	Min. Impedance (Ohm)	
					25MHz	100MHz
RH3.5x3.5x0.8W/T	3.5 ±0.20	3.5 ±0.20	63 ±3	5.0 ±0.5	25	45
RH3.5x4.7x0.8W/T	3.5 ±0.20	4.7 ±0.20	63 ±3	5.0 ±0.5	30	50
RH3.5x5x0.8W/T	3.5 ±0.20	5.0 ±0.30	63 ±3	5.0 ±0.5	30	50
RH3.5x6x0.8W/T	3.5 ±0.20	6.0 ±0.30	63 ±3	5.0 ±0.5	35	60
RH3.5x8x0.8W/T	3.5 ±0.20	8.0 ±0.30	63 ±3	5.0 ±0.5	30	80
RH3.5x9x0.8W/T	3.5 ±0.20	9.0 ±0.30	63 ±3	5.0 ±0.5	45	100

## RID Cores of Soft Ferrite

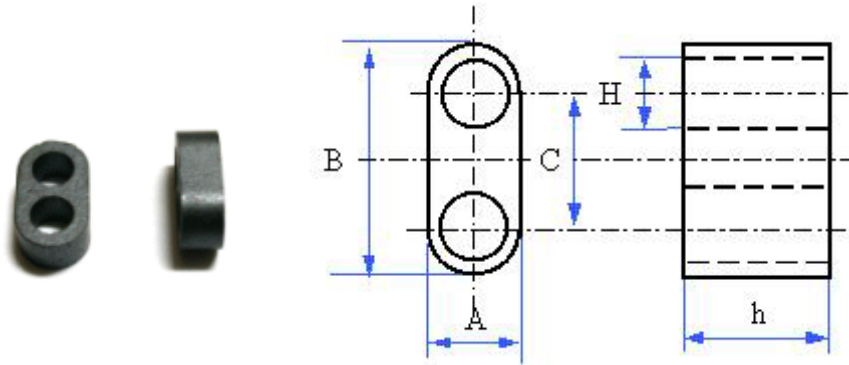

### Dimensions

Ordering Code	A(mm)	h(mm)	B(mm)	C(mm)	H(mm)
RID2×1.5×3.5	2.0 ±0.20	1.5 ±0.20	3.5 ±0.20	1.8	0.90 ±0.10
RID2×1.8×3.5	2.0 ±0.20	1.8 ±0.20	3.5 ±0.20	1.8	0.90 ±0.10
RID3×2×5	3.0 ±0.20	2.0 ±0.20	5.1 ±0.30	2.6	1.2 ±0.10
RID3×4×5	3.0 ±0.20	4.0 ±0.20	5.1 ±0.30	2.6	1.2 ±0.10
RID4×6×7	4.0 ±0.20	6.0 ±0.20	7.0 ±0.30	2.9	1.9 ±0.20
RID7.5×7×13.3	7.5 ±0.30	7.0 ±0.20	13.3 ±0.40	5.8	4.2 ±0.25

## RM Cores of Soft Ferrite

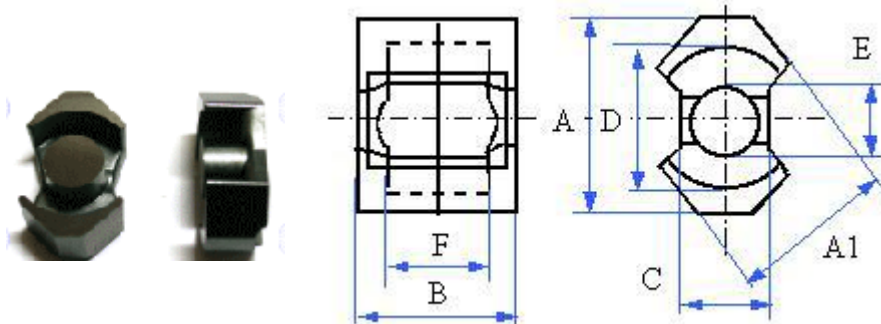

### Dimensions

Type	Dimensions (Unit: mm)						
	A	A1	B	C	D	E	F
RM5	14.30 ±0.30	12.05 ±0.25	10.40 ±0.10	4.80 ±0.20	10.40 ±0.20	4.80 ±0.10	6.50 ±0.20
RM6	17.60 ±0.30	14.40 ±0.30	12.40 ±0.10	6.60 ±0.20	12.65 ±0.25	6.30 ±0.10	8.20 ±0.20
RM8	22.75 ±0.45	19.30 ±0.40	16.40 ±0.10	8.00 ±0.20	17.30 ±0.30	8.40 ±0.15	11.00 ±0.20
RM10	27.85 ±0.65	24.15 ±0.55	18.60 ±0.10	10.80 ±0.20	21.65 ±0.45	10.70 ±0.20	12.70 ±0.30

## Core Set Parameters and Electrical Characteristics

AL-Value (nH/N<sup>2</sup> ±25%): 1kHz, 0.25V, 100Ts, 25±3°C

Type	Le (mm)	Ae (mm <sup>2</sup> )	C1 (mm <sup>-1</sup> )	Ve (mm <sup>3</sup> )	AL for Material				
					CY-MP2B	CY-MP2A	CY-HP5	CY-HP7	CY-HP10
RM5	22.1	23.8	0.9	526	-	1920	-	-	7000
RM6	28.6	36.6	0.8	1046	-	2300	-	-	9000
RM8	38.0	64.0	0.6	2432	-	3160	-	-	13000
RM10	44.0	98.0	0.4	4312	-	4030	-	-	16800

## R Cores of Soft Ferrite

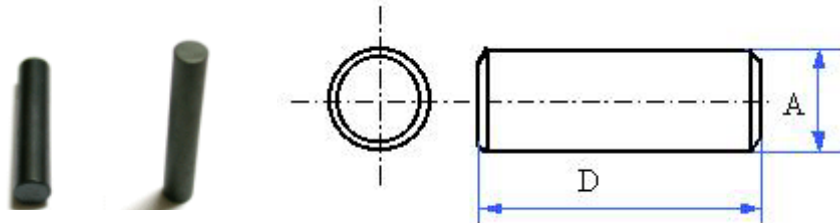

### Dimensions

Ordering Code	A (mm)	D (mm)	Ordering Code	A (mm)	D (mm)
R3x11	3.0 ±0.10	11.0 ±0.40	R3.5x25	3.5 ±0.10	25.0 ±0.80
R3x12	3.0 ±0.10	12.0 ±0.40	R3x10	3.0 ±0.10	10.0 ±0.30
R3x12.2	3.0 ±0.10	12.2 ±0.40	R3x14	3.0 ±0.10	14.0 ±0.40
R4x13	4.0 ±0.15	13.0 ±0.40	R3x25	3.0 ±0.15	25.0 ±0.80
R4x14	4.0 ±0.15	14.0 ±0.40	R4x10	4.0 ±0.15	10.0 ±0.80
R4x16	4.0 ±0.15	16.0 ±0.40	R4x12	4.0 ±0.15	12.0 ±0.80
R4x18	4.0 ±0.15	18.0 ±0.50	R5x19	5.0 ±0.15	19.0 ±0.50
R4x19	4.0 ±0.15	19.0 ±0.50	R5x20	5.0 ±0.15	20.0 ±0.60
R4x20	4.0 ±0.10	20.0 ±0.60	R5x22	5.0 ±0.15	22.0 ±0.60
R4x21	4.0 ±0.15	21.0 ±0.60	R5x23	5.0 ±0.15	23.0 ±0.60
R4x26	4.0 ±0.15	26.0 ±0.80	R5x26	5.0 ±0.15	26.0 ±0.80
R4x30	4.0 ±0.15	30.0 ±0.80	R5x18	5.0 ±0.15	18.0 ±0.50
R4x15	4.0 ±0.15	15.0 ±0.40	R5x25	5.0 ±0.15	25.0 ±0.40
R5x10	5.0 ±0.15	10.0 ±0.30	R5x30	5.0 ±0.15	30.0 ±0.80
R6x10	6.0 ±0.15	10.0 ±0.40	R6x15	6.0 ±0.15	15.0 ±0.50
R6x12	6.0 ±0.15	12.0 ±0.40	R6x16	6.0 ±0.15	16.0 ±0.50
R6x13	6.0 ±0.15	13.0 ±0.40	R6x18	6.0 ±0.15	18.0 ±0.50
R6x20	6.0 ±0.15	20.0 ±0.60	-	-	-
R5x10	5.0 ±0.15	10.0 ±0.30	R6x20	6.0 ±0.15	20.0 ±0.60
R5x13	5.0 ±0.15	13.0 ±0.40	R6x22	6.0 ±0.15	22.0 ±0.60
R5x14	5.0 ±0.15	15.0 ±0.40	R8x15	8.0 ±0.20	15.0 ±0.40
R5x15	5.0 ±0.15	15.0 ±0.50	R8x22	8.0 ±0.20	22.0 ±0.60
R5x16	5.0 ±0.15	16.0 ±0.50	R8x20	8.0 ±0.20	20.0 ±0.60
R6x25	6.0 ±0.15	25.9 ±0.80	R8x25	8.0 ±0.20	26.0 ±0.80
R6x30	6.0 ±0.15	30.0 ±0.80	R8x30	8.0 ±0.20	30.0 ±0.80
R6x31	6.0 ±0.15	31.0 ±0.80	R8x32	8.0 ±0.20	32.0 ±0.80
R6x40	6.0 ±0.15	40.0 ±0.10	R8x38	8.0 ±0.20	38.0 ±0.80
R6x38	6.0 ±0.15	38.0 ±0.80	R8x40	8.0 ±0.20	40.0 ±0.10
R10x18	10.0 ±0.20	18.0 ±0.50	R10x24	10.0 ±0.20	24.0 ±0.60

R10×20	10.0 ±0.20	20.0 ±0.60		R10×25	10.0 ±0.20	25.0 ±0.60
R10×22	10.0 ±0.20	22.0 ±0.60		R10.0×28	10.0 ±0.20	28.0 ±0.80
R10×40	10.0 ±0.20	40.0 ±1.0		R10×32	10.0 ±0.20	32.0 ±0.80
R10×30	10.0 ±0.20	30.0 ±0.80		R10×35	10.0 ±0.20	35.0 ±0.80

## SDR Cores of Soft Ferrite

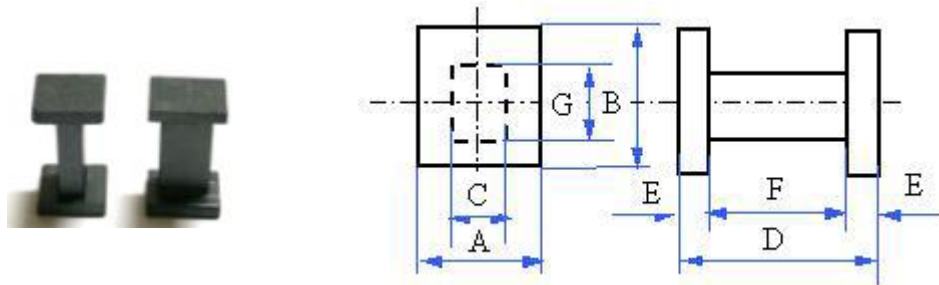

### Dimensions

Ordering Code	A	B	C	D	E	F	G
SDR10×10×19	10.00 ±0.30	10.00 ±0.30	3.60 ±0.15	19.00 ±0.60	3.25	14.50 ±0.50	6.70 ±0.30
SDR10×10.5×19	10.00 ±0.30	10.50 ±0.30	3.60 ±0.15	19.00 ±0.60	3.25	14.50 ±0.60	7.20 ±0.25

## SH Cores of Soft Ferrite

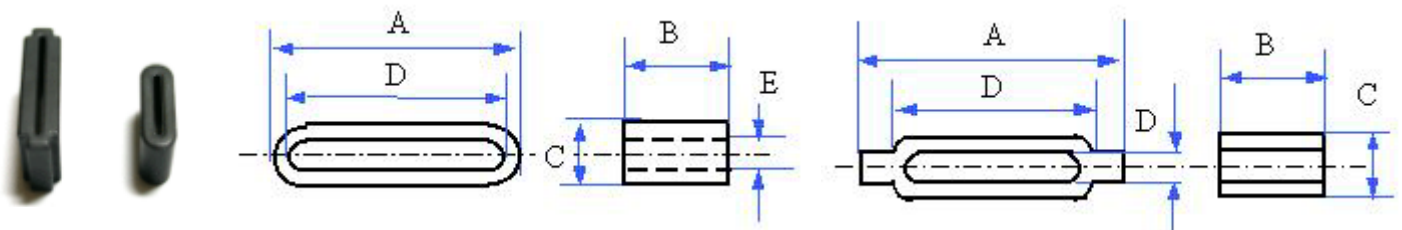

Fig. 1

Fig. 2

### Dimensions

Ordering Code	A	B	C	D	E	Fig.
SH19×12×6.5	19.00 ±0.50	12.00 ±0.40	6.50 ±0.40	13.50 ±0.40	1.50 ±0.12	1
SH26.5×15×5	26.50 ±0.60	15.00 ±0.50	5.00 ±0.25	22.50 ±0.50	0.90 ±0.15	1
SH33.5×12×6.5	33.50 ±0.80	12.00 ±0.40	6.50 ±0.25	27.00 ±0.60	1.50 ±0.15	1
SH40×12×6.5	40.00 ±0.80	12.00 ±0.40	6.50 ±0.25	35.00 ±0.80	1.50 ±0.15	1
SH45.2×12×6.5	45.20 ±0.80	12.00 ±0.40	6.50 ±0.25	40.00 ±0.80	1.30 ±0.15	1
SH28×15×7.7	28.00 ±0.60	15.00 ±0.50	7.70 ±0.25	23.00 ±0.50	1.40 ±0.15	2

## UI Cores of Soft Ferrite

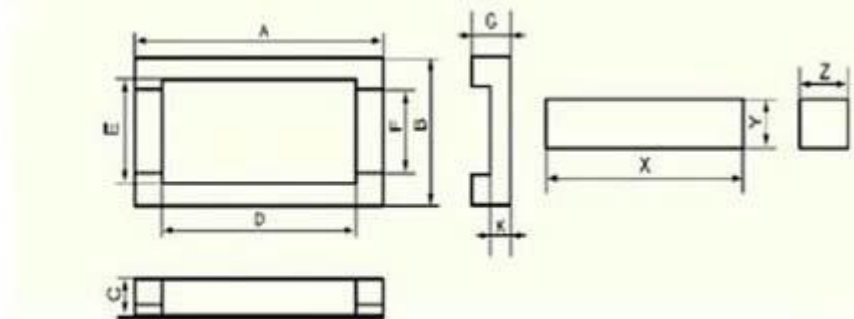

### Dimensions

Type	Dimensions (Unit: mm)							AL (nH)
	A	B	C	D	E	F	K	
UI8.3	27.4 ±0.5 x:21.8 ±0.3	8.3 ±0.2 y:5.5 ±0.2	2.95 ±0.05 z:1.8 ±0.1	22.4 ±0.5	6.5 ±0.15	5.4 ±0.1	1.05 ±0.15	250
UI10	23.8 ±0.3 x:24.1 ±0.3	9.8 ±0.2 y:4.4 ±0.1	3.85 ±0.05 z:2.0 ±0.05	19.2 ±0.3	7.3 ±0.2	5.7 ±0.1	1.3 ±0.1	370
UI12	21.0 ±0.2 x:28.3 ±0.5	11.8 ±0.2 y:3.85 ±0.1	3.5 ±0.1 z:1.35 ±0.05	16.2 ±0.15	8.9 ±0.2	7.0 ±0.1	2.3 ±0.1	400
UI15	19.7 ±0.3 x:28.3 ±0.3	14.8 ±0.3 y:7.9 ±0.2	4.6 ±0.1 z:1.9 ±0.1	15.6 ±0.3	11.4 ±0.25	7.0 ±0.1	1.85 ±0.05	500
UI17	28.3 ±0.5 x:19.9 ±0.3	16.65 ±0.25 y:4.45 ±0.15	3.7 ±0.15 z:4.45 ±0.15	20.3 ±0.3	12.6 ±0.15	9.8 ±0.2	1.8 ±0.15	450

## UF/UU Cores of Soft Ferrite

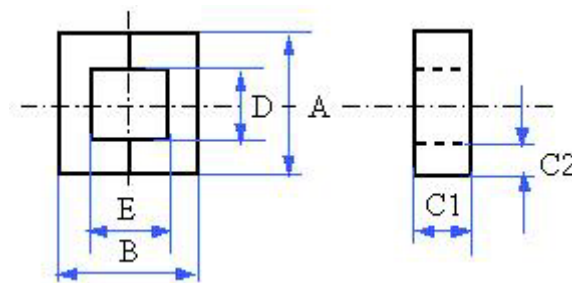

## Dimensions

Type	Dimensions (Unit: mm)						weight (g)
	A	B	C1	C2	D	E	
UF8.6	8.6 ±0.2	12.9 ±0.4	3.6 ±0.2	2.2 ±0.15	4.0 <sub>min</sub>	8.2 ±0.4	1.3
UF9.8	9.8 ±0.3	14.2 ±0.4	2.9 ±0.2	2.9 ±0.2	4.1 <sub>min</sub>	8.6 ±0.4	1.4
UF10	10.1 ±0.3	15.0 ±0.5	2.9 ±0.2	2.95 ±0.15	3.9 <sub>min</sub>	9.0 ±0.5	1.5
UF10.5	10.5 ±0.3	15.6 ±0.4	5.0 ±0.3	2.4 ±0.2	5.2 <sub>min</sub>	10.6 ±0.4	2.8
UF11	11.0 ±0.3	15.6 ±0.4	5.2 ±0.2	2.8 ±0.2	5.4 <sub>min</sub>	11.0 ±0.4	2.8
UF11.5	11.5 ±0.3	28.6 ±0.6	4.8 ±0.3	3.9 ±0.3	3.65 <sub>min</sub>	21.0 ±0.6	5.7
UF13	13.5 ±0.3	19.8 ±0.5	5.0 ±0.2	3.5 ±0.2	6.5 <sub>min</sub>	12.2 ±0.4	4.1
UF15	15.2 ±0.5	22.8 ±0.4	6.4 ±0.3	5.1 ±0.20	5.0 <sub>min</sub>	12.8 ±0.4	9.0
UF15A	15.85 ±0.35	20.0 ±0.4	5.0 ±0.25	3.3 ±0.2	9.3 <sub>min</sub>	13.7 ±0.4	8.9
UF15.7	15.7 ±0.3	19.4 ±0.5	6.0 ±0.3	4.5 ±0.2	6.3 <sub>min</sub>	12.0 ±0.5	6.5
UF16	16.0 ±0.4	20.0 ±0.4	6.0 ±0.2	4.6 ±0.2	6.7 <sub>min</sub>	12.0 ±0.4	7.4
UF17	17.0 ±0.35	19.5 ±0.4	8.5 ±0.2	3.6 ±0.2	9.85 <sub>min</sub>	12.5 ±0.4	9.8
UU20	20.0 ±0.4	24.5 ±0.4	9.0 ±0.2	5.6 ±0.3	8.8 <sub>min</sub>	13.9 ±0.4	15.4
UF20	19.7 ±0.4	35.4 ±0.4	6.0 ±0.2	6.0 ±0.2	7.4 <sub>min</sub>	23.4 ±0.4	15
UF21	21.7 ±0.3	32.0 ±0.5	8.0 ±0.2	7.35 ±0.2	6.8 <sub>min</sub>	15.0 ±0.4	22.6
UF30	30 ±0.6	24.2 ±0.4	6.2 ±0.2	6.2 ±0.3	17.0 <sub>min</sub>	12.2 ±0.4	15.3

## Core Set Parameters and Electrical Characteristics

AL-Value (nH/N<sup>2</sup> ±25%): 1kHz, 0.25V, 100Ts, 25±3°C

Type	Le (mm)	Ae (mm <sup>2</sup> )	C1 (mm <sup>-1</sup> )	Ve (mm <sup>3</sup> )	AL for Material				
					CY-MP2B	CY-MP2A	CY-HP5	CY-HP7	CY-HP10
UF8.6	32.2	7.8	4.1	251.9	-	-	-	-	960
UF9.8	34.1	7.65	4.5	260.9	500	450	1010	1050	1460
UF10	35.7	8.6	4.15	307	-	-	-	1005	1100
UF10.5	40.5	12.4	3.3	502.2	700	650	1250	1450	2250
UF11	40.8	27.54	1.5	1129	1500	1400	-	-	-
UF11.5	61.4	37.1	1.7	2277	1330	1270	-	-	-
UF13	44.7	22.5	2	1007	1130	1080	-	-	-
UF15	51.7	31.9	1.6	1649.2	1350	1250	2600	3150	4450
UF15A	56.1	32.1	1.75	1801	1290	1230	-	-	-
UF15.7	50	24.8	2.01	1240	-	-	-	2600	-
UF16	51.2	25.6	2.0	1310.7	1100	1000	2150	2600	3600
UF17	55.8	60.1	0.9	3354	2500	2400	-	-	-
UU20	62.5	97.8	0.64	6114	3500	3380	-	-	-
UF20	81	36	2.25	2916	-	-	2100	2750	3800
UF21	68.9	126.8	0.54	8737	4010	3900	-	-	-
UF30	77.9	38.3	2.04	2986	-	-	3080	4300	6150